

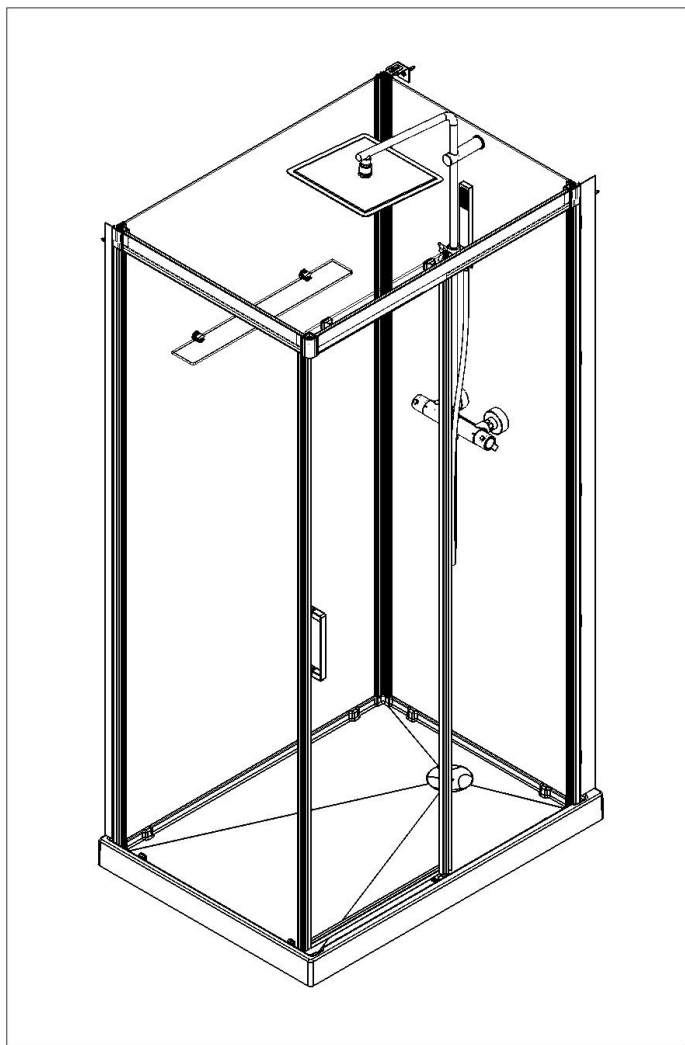

- F Notice de montage ● GB Installation instructions
- E Manual de instalación ● I Istruzioni di montaggio
- NL Montage-instructies ● D Montageanleitung





Attention aux étapes :
 Check installation steps :
 Atención a los pasos :
 Attenzione ai passi :
 Aandacht voor de stappen :
 Achtung vor den Schritten :

P. 15 - 16 - 19

TAILLE 110
TAILLE 120

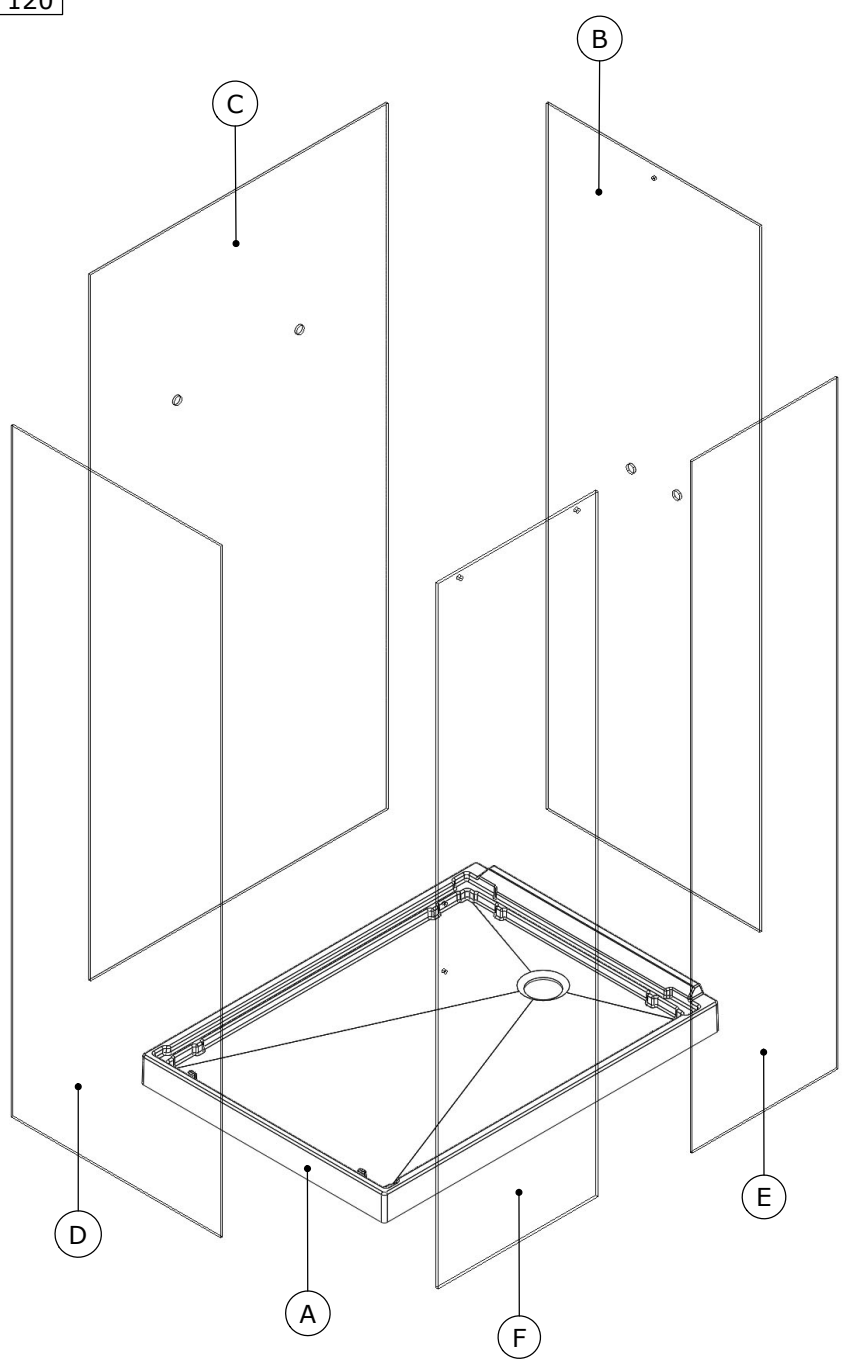

TAILLE 160
TAILLE 170

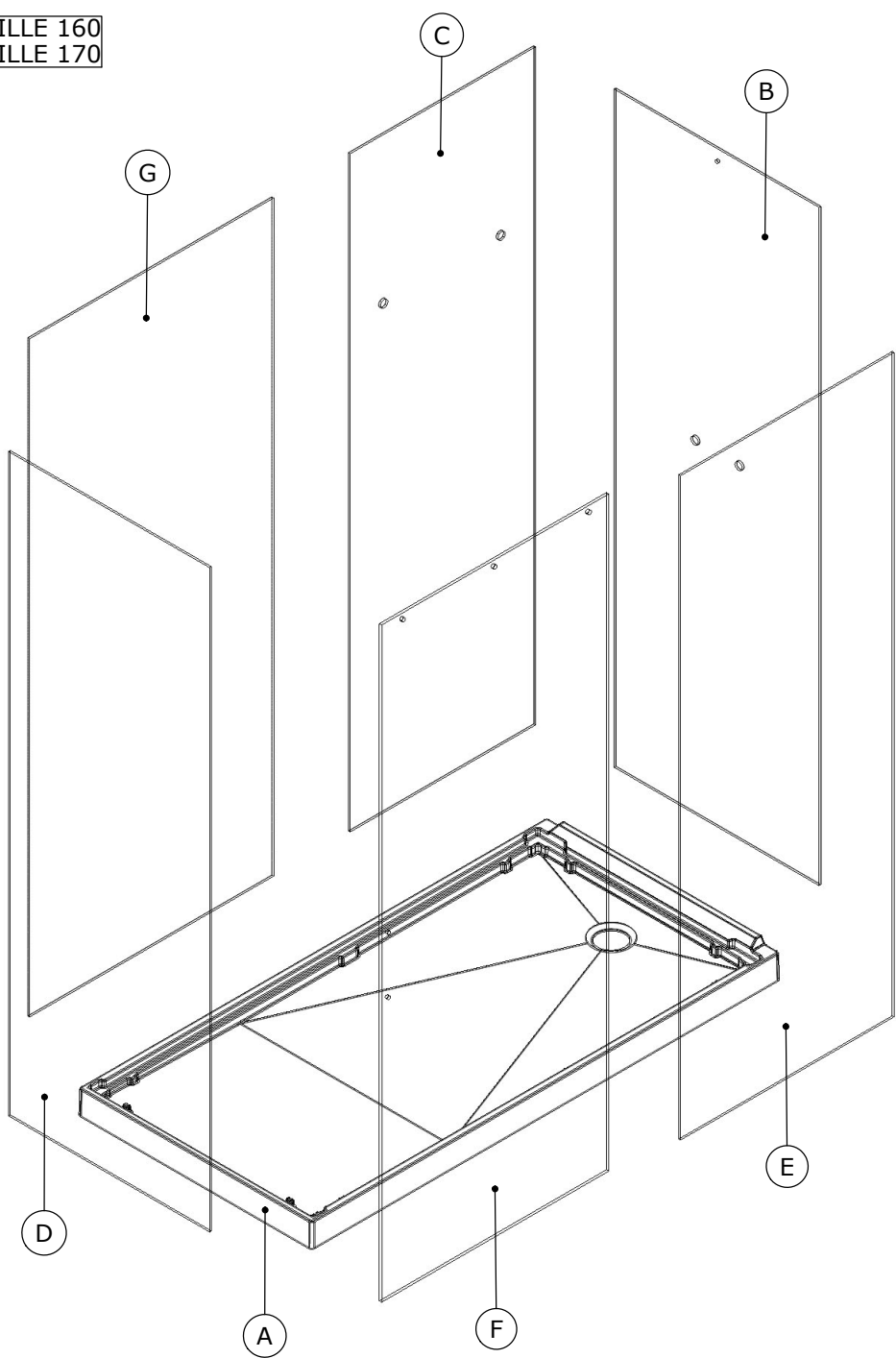

- **CODE COLIS** (Voir repères en page 2 - 3)
- **PACKAGE CODES** (See marks on page 2 - 3)
- **REF. BULTOS** (Ver pg. 2 - 3 para listado de bultos)
- **CODE SET** (zie blz. 2 - 3)
- **Codering verpakking** (zie omschrijving op pagina 2 - 3)
- **PAKETCODES** (siehe Kennzeichnungen auf Seite 2 - 3)

REP	VERSION	110X80	120X90	160X80	170X80
A	X	REC603	REC604	REC605	REC606
B	GRIS	C13970E	C13971E	C13970E	C13970E
	NOIR	C13970E	C13971E	C13970E	C13970E
C	GRIS	C11489E	C11565E	C11569E	C11572E
	NOIR	C11489E	C11565E	C11569E	C11572E
D	GRIS	C13837E	C13834E	C13837E	C13837E
	NOIR	C13833E	C13835E	C13833E	C13833E
E	GRIS	C13810E	C13812E	C13814E	C13816E
	NOIR	C13811E	C13813E	C13815E	C13817E
F	GRIS	C13825E	C13827E	C13829E	C13831E
	NOIR	C13826E	C13828E	C13830E	C13832E
G	GRIS	X	X	C11699E	C11702E
	NOIR	X	X	C11699E	C11702E

Autres pièces:

(voir pages suivantes)

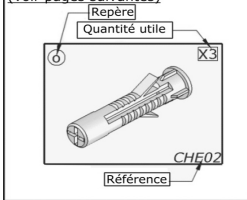
**Other parts:**

(see next pages)

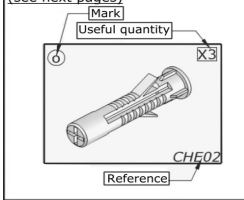
**Otras piezas:**

(ver páginas siguientes)



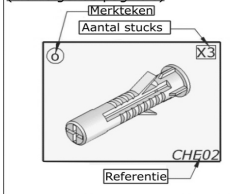

**Andere onderdelen:**



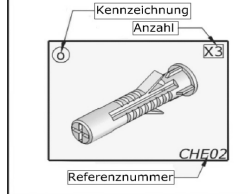

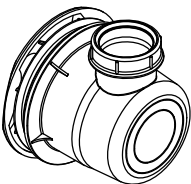
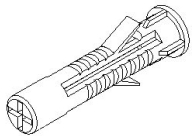
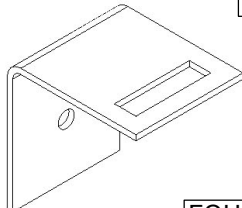
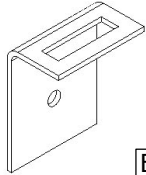
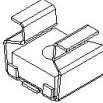
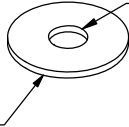
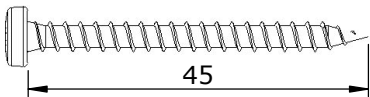

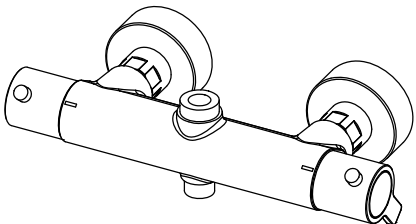
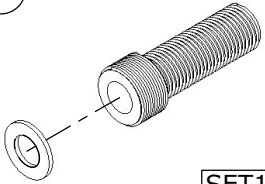
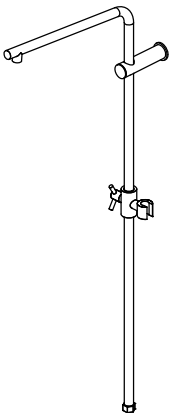
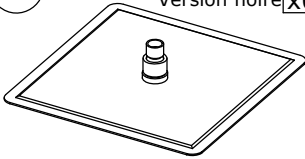
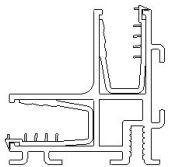
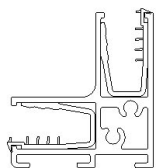
(zie volgende pagina's)

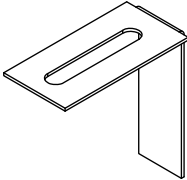
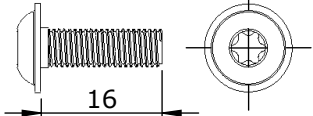
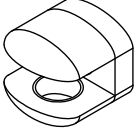
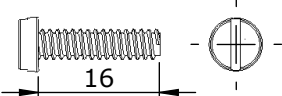
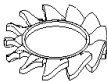

**Weitere beigeppackte:**

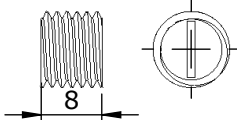
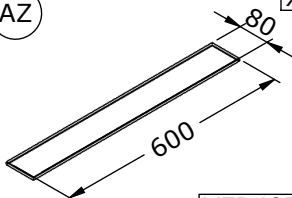
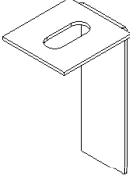
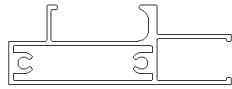
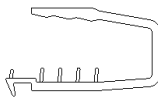
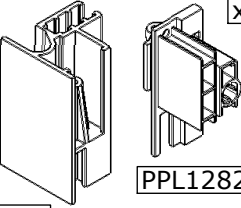

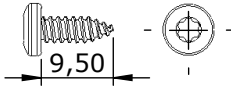
(teile finden Sie auf der nächsten Seite)

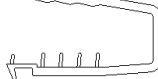
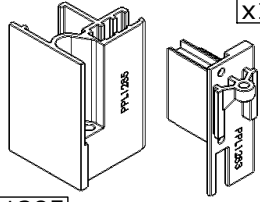

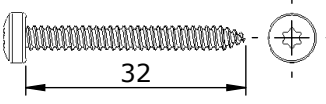
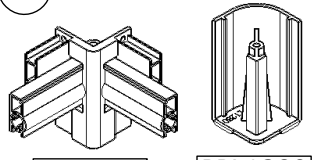
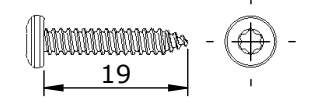
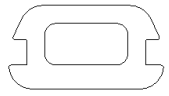
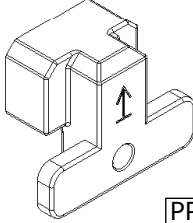
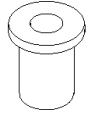
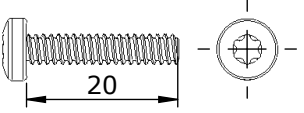
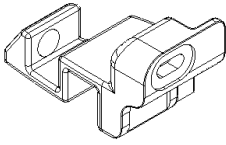
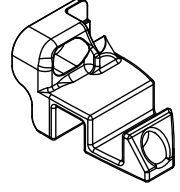
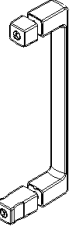
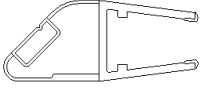
<p>AA x1</p>  <p style="text-align: right;">BOND07</p>	<p>AB 110/120 x3 160/170 x4</p>  <p style="text-align: right;">CHE02</p>	<p>AC x2</p>  <p style="text-align: right;">EQU24</p>
<p>AD 110/120 x1 160/170 x2</p>  <p style="text-align: right;">EQU76</p>	<p>AE 110/120 x3 160/170 x4</p>  <p style="text-align: right;">ECR46</p>	<p>AF x2</p>  <p style="text-align: right;">RON51</p>
<p>AG Ø4</p>  <p style="text-align: right;">VIS231</p>	<p>AI x2</p>  <p style="text-align: right;">PPL1318</p>	
<p>AJ Version grise x1 Version noire x0</p>  <p style="text-align: right;">MIT89</p>	<p>AL x2</p>  <p style="text-align: right;">SET169</p>	
<p>AM Version grise x1 Version noire x0</p>  <p style="text-align: right;">KIT181</p>	<p>AN Version grise x1 Version noire x0</p>  <p style="text-align: right;">KIT202</p>	<p>AO x1</p>  <p style="text-align: right;">Lg=2000mm 6189</p>
<p>AP x2</p>  <p style="text-align: right;">Lg=1941mm 6232</p>	<p>AQ 110/120 x2 160/170 x4</p>  <p style="text-align: right;">Lg=1996mm P134</p>	

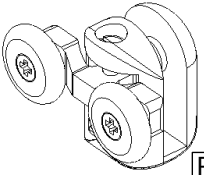
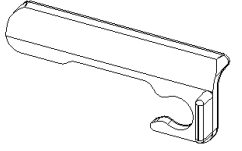
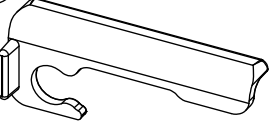
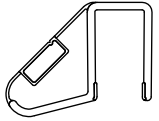
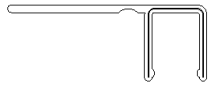
<p>(AR) x4</p>  <p>Lg=1937mm P133</p>	<p>(AS) x2</p>  <p style="text-align: right;">EQU50</p>	<p>(AT) M5 110/120 x3 160/170 x4</p>  <p style="text-align: right;">VIS229</p>
<p>(AU) x2</p>  <p style="text-align: right;">PIN07</p>	<p>(AV) M4 x2</p>  <p style="text-align: right;">VIS53</p>	<p>Version grise x2 Version noire x3</p>  <p style="text-align: right;">RON02</p>
<p>(AX) x2</p>  <p style="text-align: right;">ECR09</p>	<p>(AY) M10 x3</p>  <p style="text-align: right;">VIS07</p>	<p>(AZ) x1</p>  <p style="text-align: right;">VER4973</p>
<p>(BA) 110/120 x1 160/170 x2</p>  <p style="text-align: right;">EQU77</p>	<p>(BB) x1</p>  <p>110 - Lg=674mm 120 - Lg=774mm 160 - Lg=674mm 170 - Lg=674mm 6233</p>	<p>(BC) x2</p>  <p>110 - Lg=663mm J736 120 - Lg=763mm J758 160 - Lg=663mm J736 170 - Lg=663mm J736</p>
<p>(BD) x1</p>  <p style="text-align: right;">PPL1282</p> <p>PPL1284</p>	<p>(BE) x4</p>  <p style="text-align: right;">BUT20</p>	<p>(BF) Ø3.5 x8</p>  <p style="text-align: right;">VIS237</p>
<p>(BG) x2</p>  <p>110 - Lg=949mm 120 - Lg=1049mm 160 - Lg=1449mm 170 - Lg=1549mm 6233</p>	<p>(BH) x2</p>  <p>110 - Lg=450mm J735 120 - Lg=500mm J759 160 - Lg=700mm J760 170 - Lg=750mm J742</p>	<p>(BI) x1</p>  <p>PPL1285 PPL1283</p>

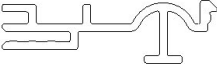
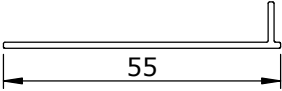
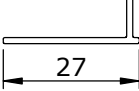
<p>(BJ) $\varnothing 3.5$ x4</p>  <p>32</p> <p>VIS214</p>	<p>(BK) x1</p>  <p>PPL1281 PPL1280</p>	<p>(BL) $\varnothing 3.5$ x3</p>  <p>19</p> <p>VIS215</p>
<p>(BN) x1</p>  <p>110 - Lg=487mm P127 120 - Lg=537mm P128 160 - Lg=737mm P143 170 - Lg=787mm P120</p>	<p>(BO) x1</p>  <p>PPL550</p>	<p>(BP) x1</p>  <p>ECR14</p>
<p>(BQ) M4 x1</p>  <p>20</p> <p>VIS226</p>	<p>(BS) x1</p>  <p>PPL1174</p>	<p>(BT) x1</p>  <p>PPL1175</p>
<p>(BU) x1</p>  <p>PGN50</p>	<p>(BV) x1</p>  <p>Lg=1940mm AI151</p>	<p>(BW) x1</p>  <p>Lg=1997mm J443</p>
<p>(BX) x1</p>  <p>110 - Lg=508mm J441 120 - Lg=558mm J821 160 - Lg=758mm J776 170 - Lg=808mm J805</p>	<p>(BY) $\begin{matrix} 110/120 & \times 2 \\ 160/170 & \times 3 \end{matrix}$</p>  <p>ROU37</p>	<p>(BZ) x1</p>  <p>PPL1080</p>
<p>(CA) x1</p>  <p>PPL1081</p>	<p>(CB) x1</p>  <p>Lg=1938mm AIM50</p>	<p>(CC) x1</p>  <p>Lg=1935mm J724</p>

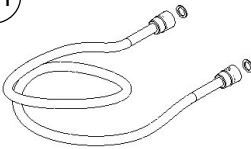
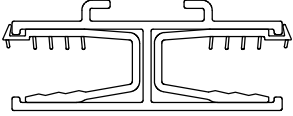
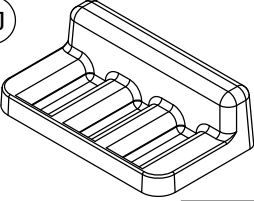
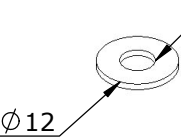
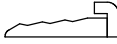
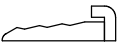
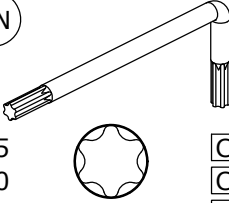
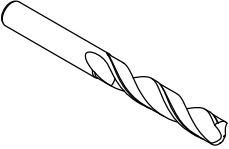
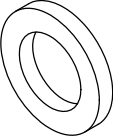
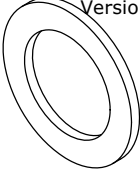
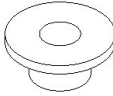
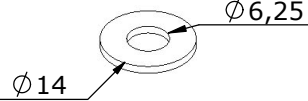
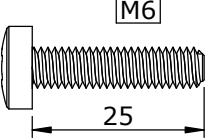
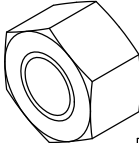
<p>(CD) x10</p>  <p style="text-align: right;">PPL1225</p>	<p>(CE) x1</p>  <p style="text-align: center;">55</p> <p>Lg=1940mm 6240</p>	<p>(CF) x1</p>  <p style="text-align: center;">27</p> <p>Lg=1935mm 6241</p>
<p>(CG) x1</p>  <p style="text-align: right;">KIT76</p>	<p>(CH) x1</p>  <p style="text-align: right;">FLEX05</p>	<p>(CI) 160/170 x1</p>  <p>Lg=2000mm 6190</p>
<p>(CJ) x1</p>  <p style="text-align: right;">PPL1141</p>	<p>(CK) 110/120 x3 160/170 x4</p>  <p style="text-align: center;">$\phi 12$ $\phi 5.2$</p> <p style="text-align: right;">RON34</p>	<p>(CL) x1</p>  <p>110 - Lg=663mm P136 120 - Lg=763mm P146 160 - Lg=663mm P136 170 - Lg=663mm P136</p>
<p>(CM) x1</p>  <p>120 - LG=450mm P144 120 - Lg=500mm P145 160 - Lg=700mm P137 170 - Lg=750mm P147</p>	<p>(CN) x1</p>  <p>T15 CLE11 T20 CLE07 T30 CLE13</p>	<p>(CO) Ø8 x1</p>  <p style="text-align: right;">FORET02</p>
<p>(CP) Version grise x1 Version Noire x0</p>  <p style="text-align: right;">JOI223</p>	<p>(CQ) Version grise x1 Version Noire x0</p>  <p style="text-align: right;">JOI283</p>	<p>(CR) Version grise x1 Version Noire x0</p>  <p style="text-align: right;">ENT15</p>
<p>(CS) Version grise x1 Version Noire x0</p>  <p style="text-align: center;">$\phi 14$ $\phi 6,25$</p> <p style="text-align: right;">RON49</p>	<p>(CT) Version grise x1 Version Noire x0</p>  <p style="text-align: center;">M6 25</p> <p style="text-align: right;">VIS262</p>	<p>(CU) Version grise x0 Version Noire x1</p>  <p style="text-align: right;">ECRORD</p>

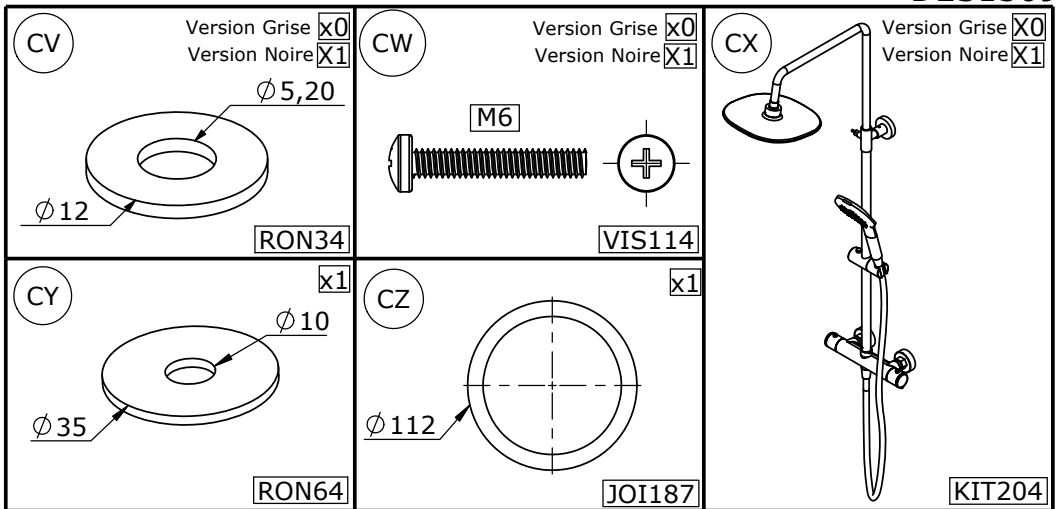

- Les quantités données sont les quantités utiles au montage. les sachets fournis contiennent des pièces supplémentaires.
- The quantities given are what are required for the installation. There may be some surplus in the package provide.
- Las cantidades indicadas son las cantidades necesarias para el montaje. Las bolsitas incluidas contienen piezas suplementarias.
- Le quantità fornite sono le quantità necessarie al montaggio. I sacchetti forniti contengono pezzi supplementari.
- De aangegeven aantallen zijn bestemd voor de montage. De bijgeleverde zakjes bevatten extra onderdelen
- Die Mengenangaben beziehen sich auf die für die Montage nötigen Teile. Eventuell weitere beige packte Teile ignorieren.

● Outillage nécessaire ● Tools required ● Equipamiento necesario
● Attrezzatura necessaria ● Benodigde gereedschap ● Werkzeuge erforderlich

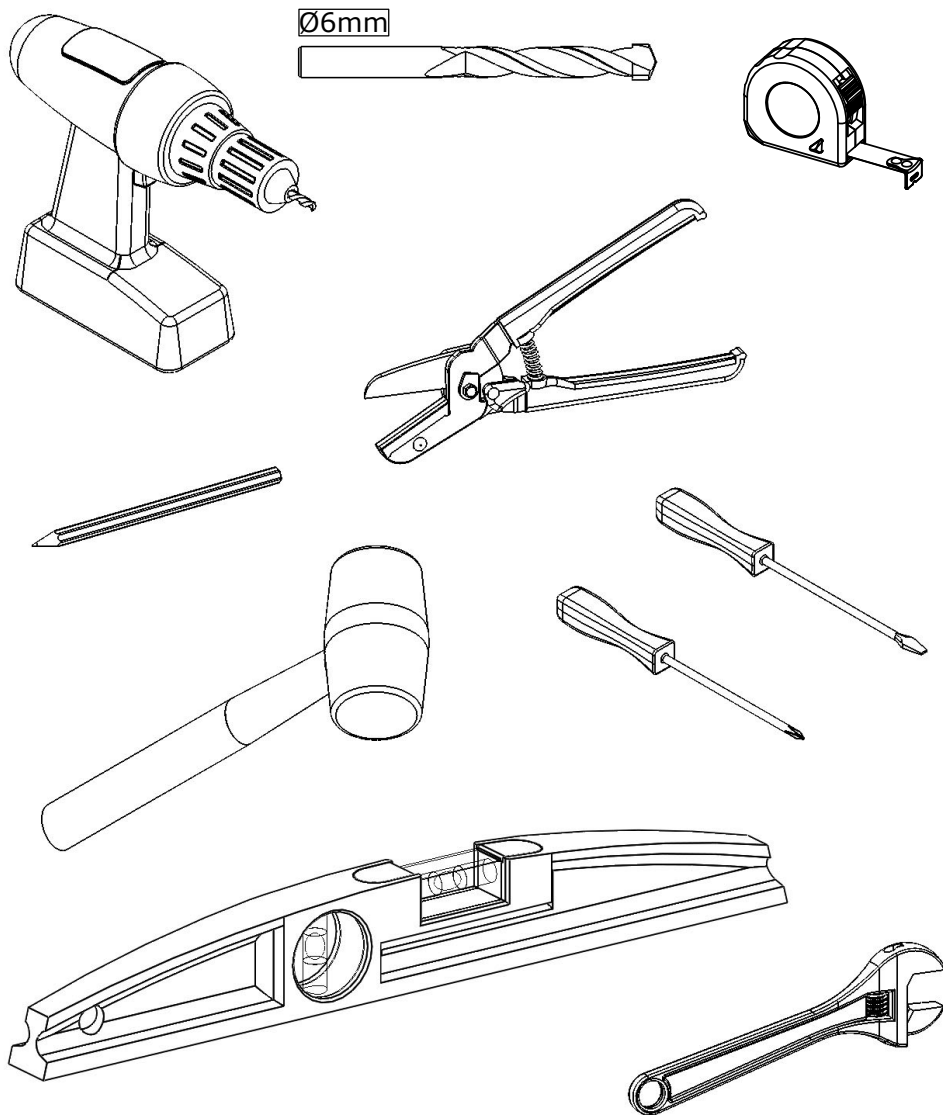

F REVERSIBILITE **GB** REVERSIBILITY **E** REVERSIBILIDAD
I REVERSIBILITA **NL** OMKEERBAARHEID **D** WAHLWEISE MONTAGE

F MONTAGE A GAUCHE
GB LEFT HAND
E MONTAJE A LA IZQUIERDA
I MONTAGGIO A SINISTRA
NL MONTAGE LINKS
D MONTAGE LINKS

F MONTAGE A DROITE
GB RIGHT HAND
E MONTAJE A LA DERECHA
I MONTAGGIO A DESTRA
NL MONTAGE RECHTS
D MONTAGE RECHTS

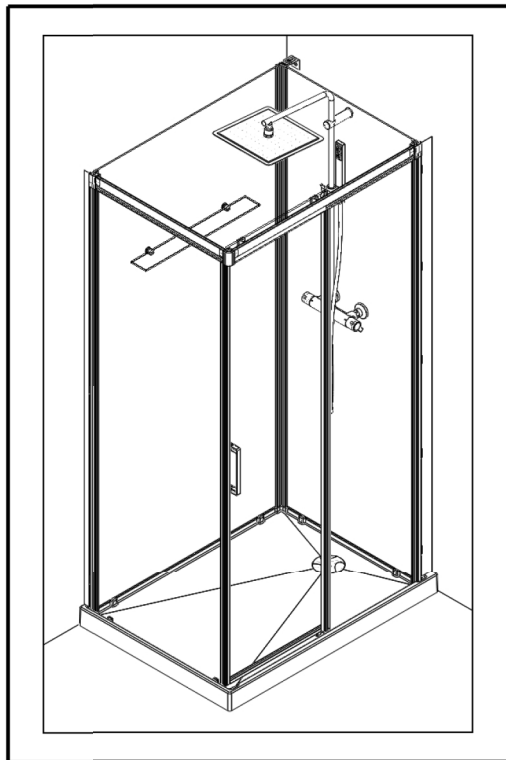
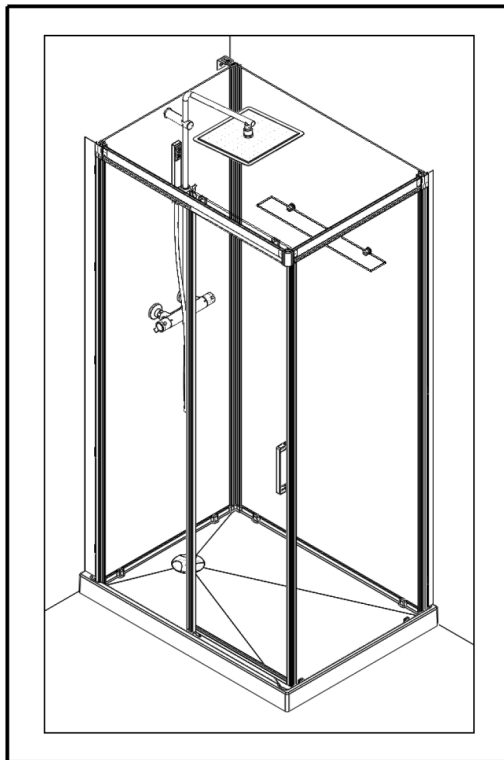

F Vous avez la possibilité de réaliser un montage à droite ou un montage à gauche. Notre notice d'installation décrit un montage à droite. Si vous voulez réaliser un montage à gauche, il vous suffit d'inverser le montage.

GB This cubicle can be installed either left or right hand. These installation instructions show a right hand installation.

E Puede realizar un montaje a la derecha o un montaje a la izquierda. Nuestro folleto de instalación describe un montaje a la derecha. Si desea montar su cabina a la izquierda sólo tendrá que realizar el montaje al contrario.

I Avete la possibilità di effettuare il montaggio a destra o a sinistra. Il nostro manuale descrive il montaggio a destra. Se volete realizzare il montaggio a sinistra è sufficiente invertire varie fasi di montaggio.

NL U kunt de douchecabine rechts of links monteren. Onze handleiding beschrijft de installatie aan de rechterkant van de cabine. Keer de montage om als u de cabine aan de linkerkant wilt monteren.

D Sie haben die Möglichkeit, eine Montage auf der linken Seite oder eine Montage auf der rechten Seite durchzuführen. Unsere Montageanleitung beschreibt eine Montage auf der rechten Seite. Wenn Sie die Montage lieber auf der linken Seite durchführen wollen, müssen Sie nur den Montageprozess umkehren.

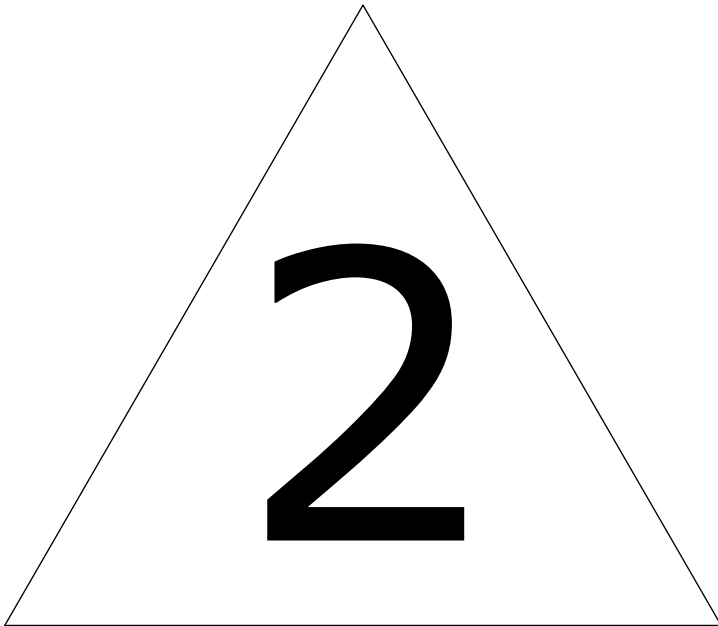
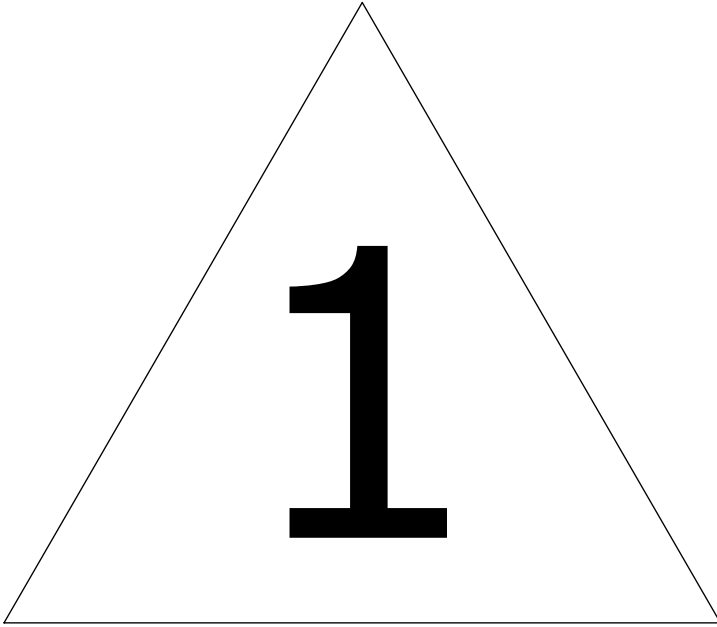

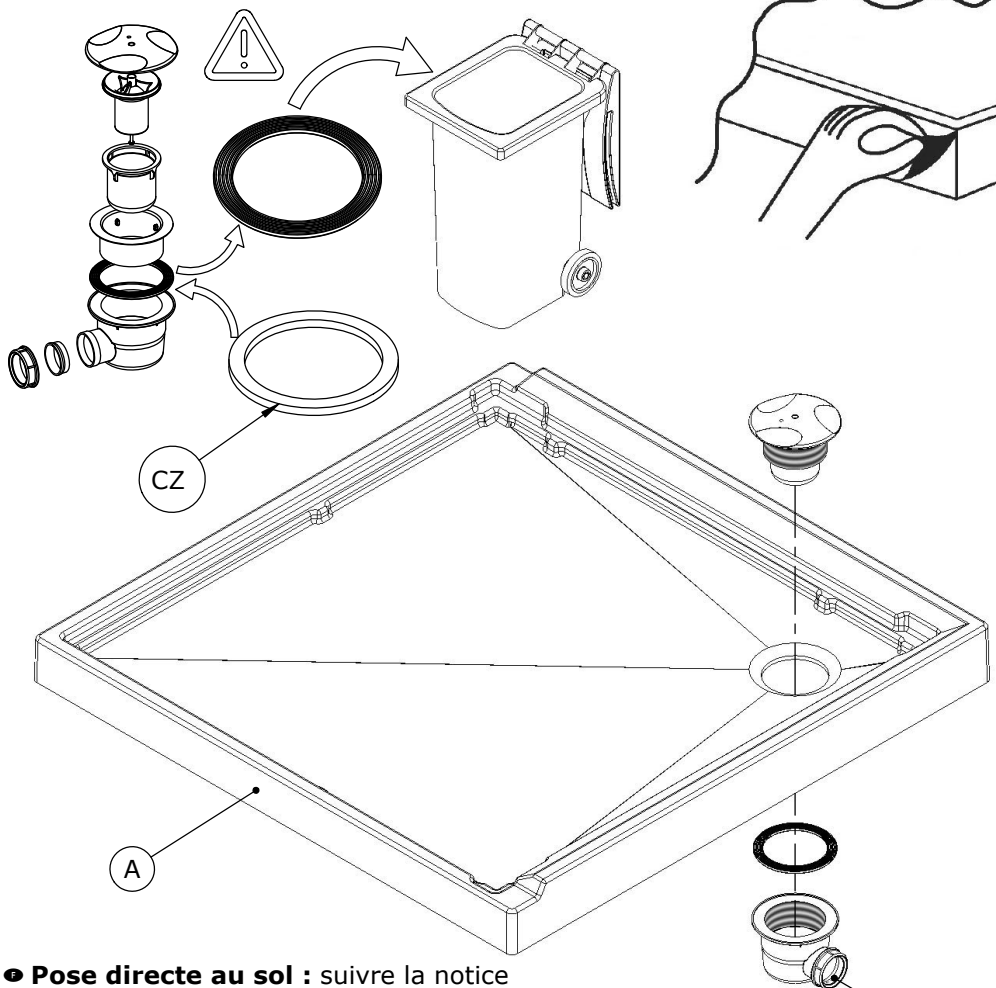

- **Pose directe au sol** : suivre la notice
- **Direct installation on the floor** : Follow the instructions
- **Instalación directa al suelo** : Continuar las instrucciones
- **Installazione diretta a terra** : Continua le istruzioni
- **Installatie rechtstreeks op de grond** : Volg de handleiding
- **Direkte Installation am Boden** : Folgen Sie genauestens der Anleitung

- **Pose sur pieds** : voir la notice spécifique à la pose des pieds
- **Installation on adjustable feet** : See the specific instructions for the installation of adjustable feet
- **Instalación sobre pies ajustables** : Consulte las instrucciones específicas para la instalación de los pies ajustables
- **Installazione su piedi regolabili** : Vedere le istruzioni specifiche per l'installazione dei piedini regolabili
- **Installatie op stelpoten** : Zie de specifieke instructies voor de installatie op stelpoten
- **Installation auf verstellbaren Füßen** : Beachten Sie die spezifischen Anweisungen für die Installation auf verstellbaren Füßen

F Pose directe au sol - MAP

- GB** Direct installation on the floor - adhesive mortar
- E** Instalación directa al suelo - mortero adhesivo
- I** Installazione diretta a terra - malta adesiva
- NL** Installatie rechtstreeks op de grond - kleefmortel
- D** Direkte Installation am Boden - Klebemörtel

CARRE 90X90

1/4 RD 90X90

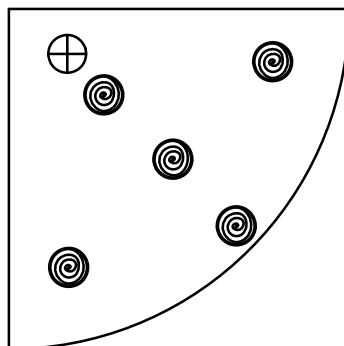
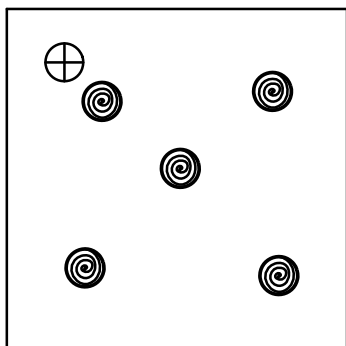

RECT. 110X80

RECT. 120X90

RECT. 160X80

RECT. 170X80

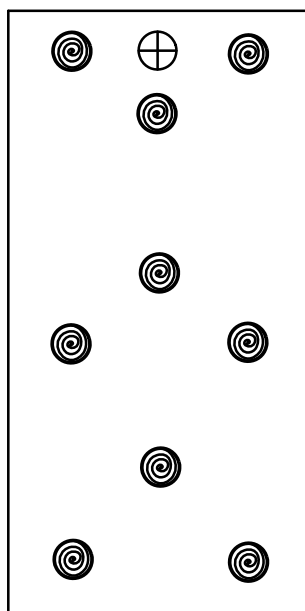
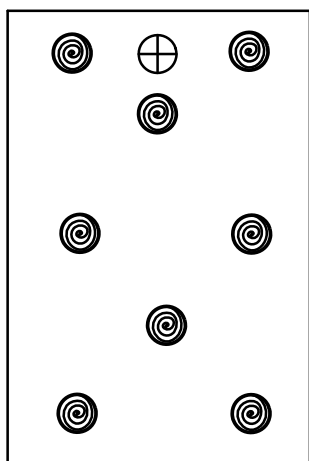

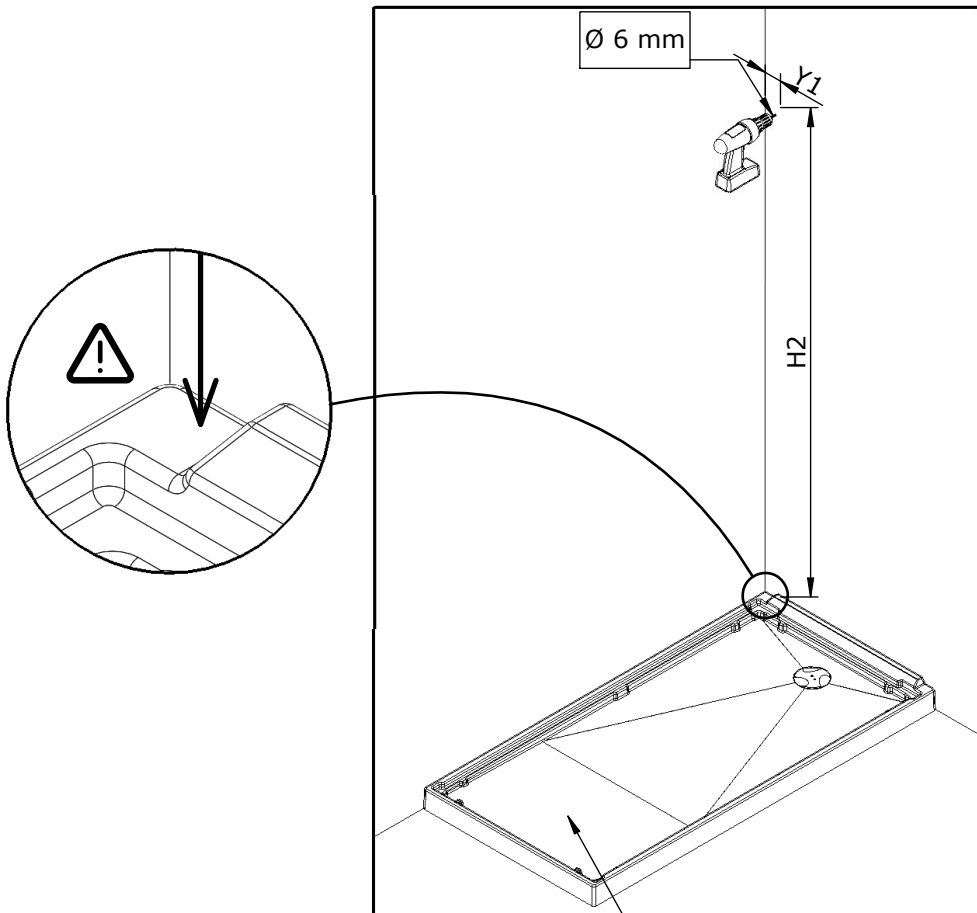

- Protéger le receveur
- Protect the shower tray
- Proteger el plato
- Proteggere il piatto
- Bescherm de douchebak
- Duschtasse schützen

Taille	110x80	160x80	170x80	120x90
H2	1942	1942	1942	1942
Y1	48	48	48	48

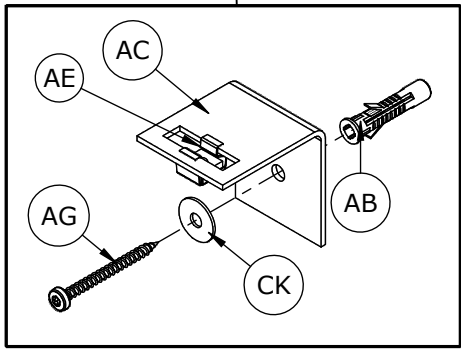
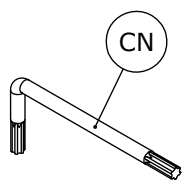
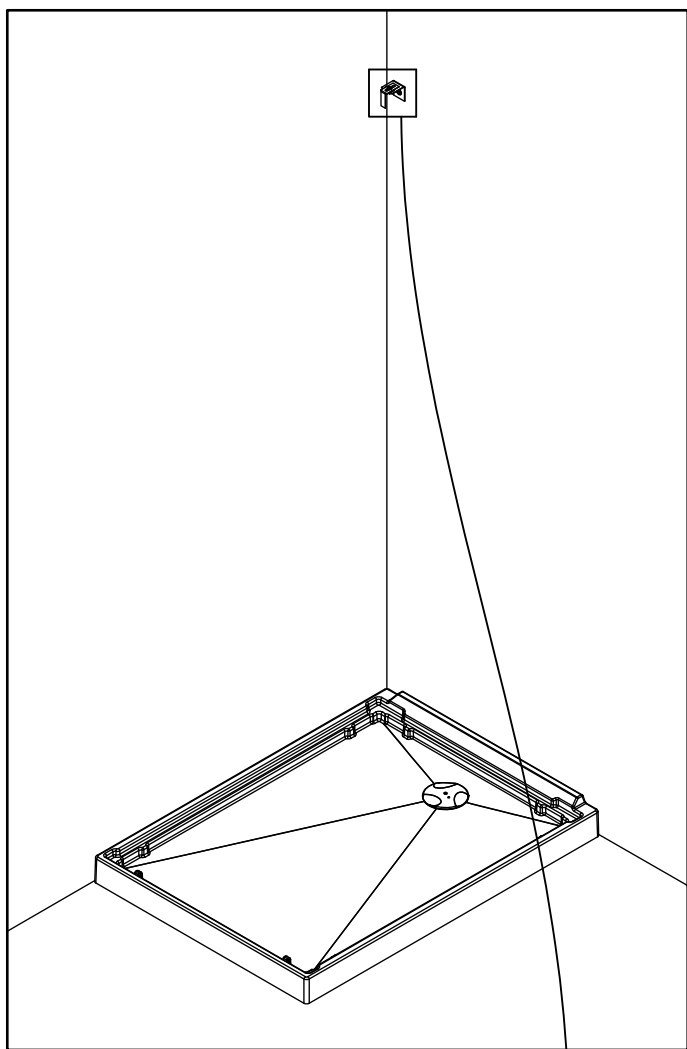

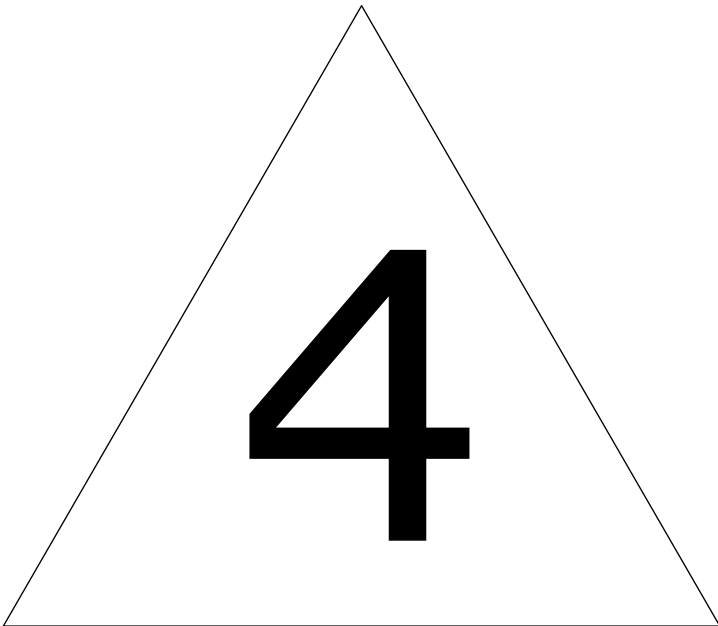
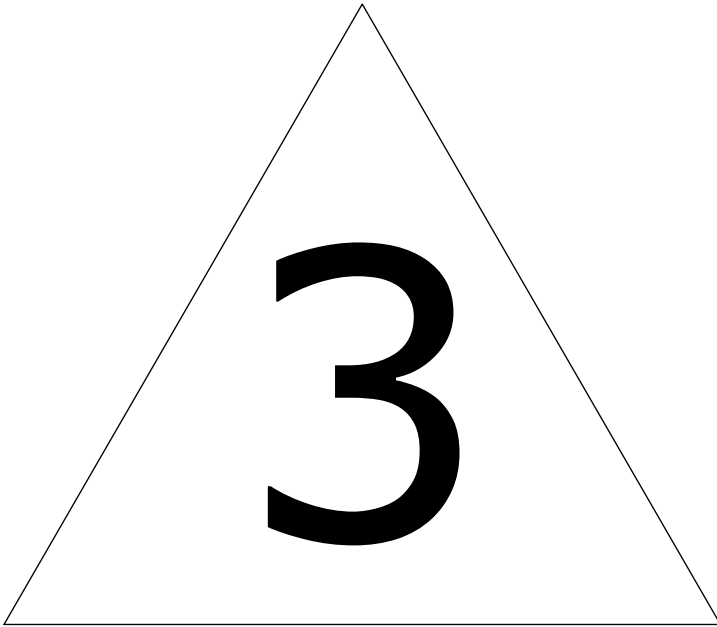

- F Version grise
- GB Gray version
- E Versión gris
- I Versione grigia
- NL Grijze Versie
- D Graue Version

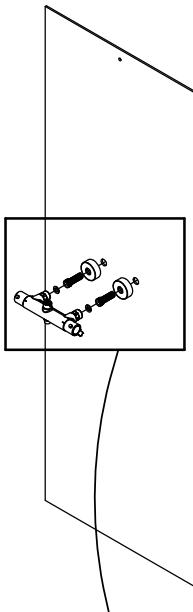

- F Voir page 21 pour version noire
- GB See page 21 for black version
- E Ver página 21 para la versión negra
- I Vedi pagina 21 per la versione nera
- NL Zie pagina 21 voor de zwarte versie
- D Siehe Seite 21 für die schwarze Version

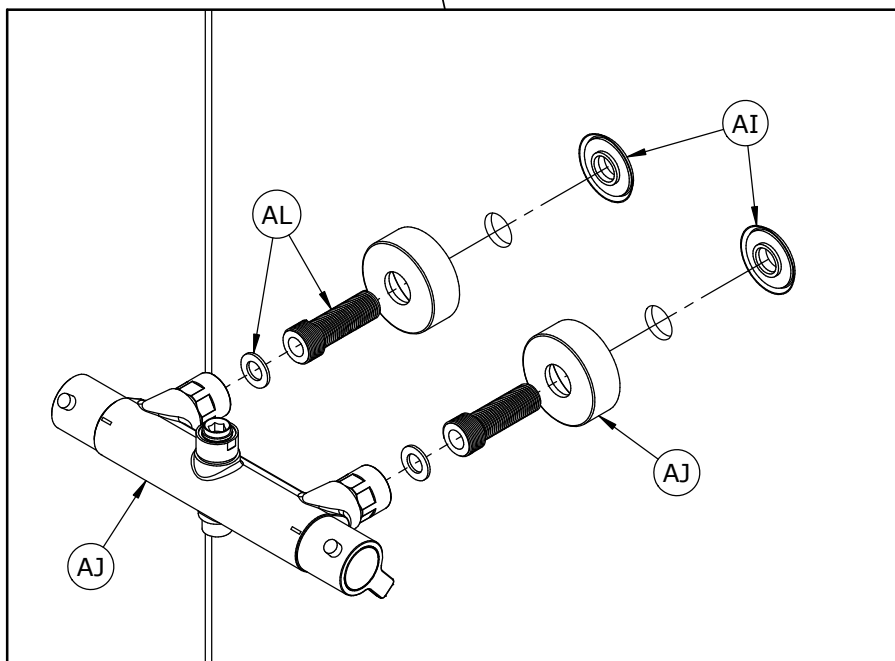

- Sérigraphie à l'extérieur
- Screen printing on the outside
- Impresión en el fuera
- Serigrafía esterna
- Glas-print aan buitenzijde
- Siebdruck außen

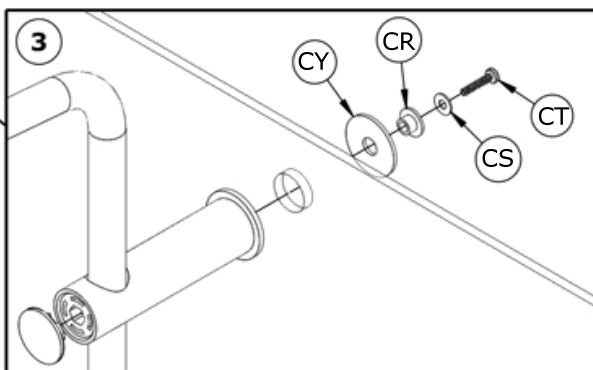
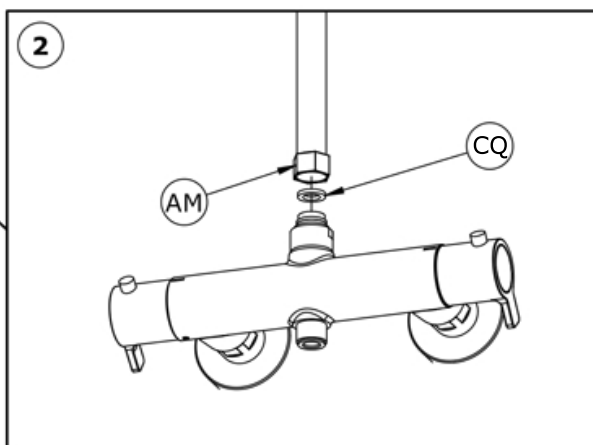
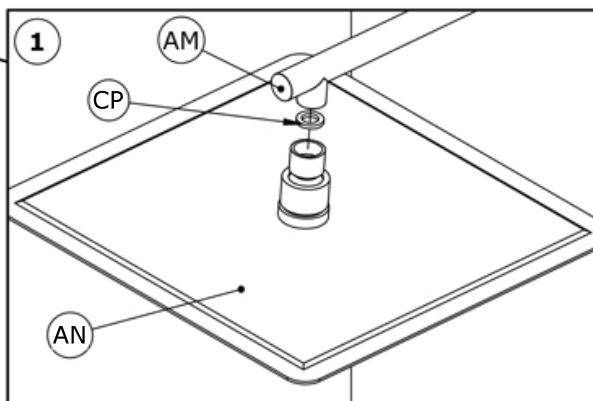

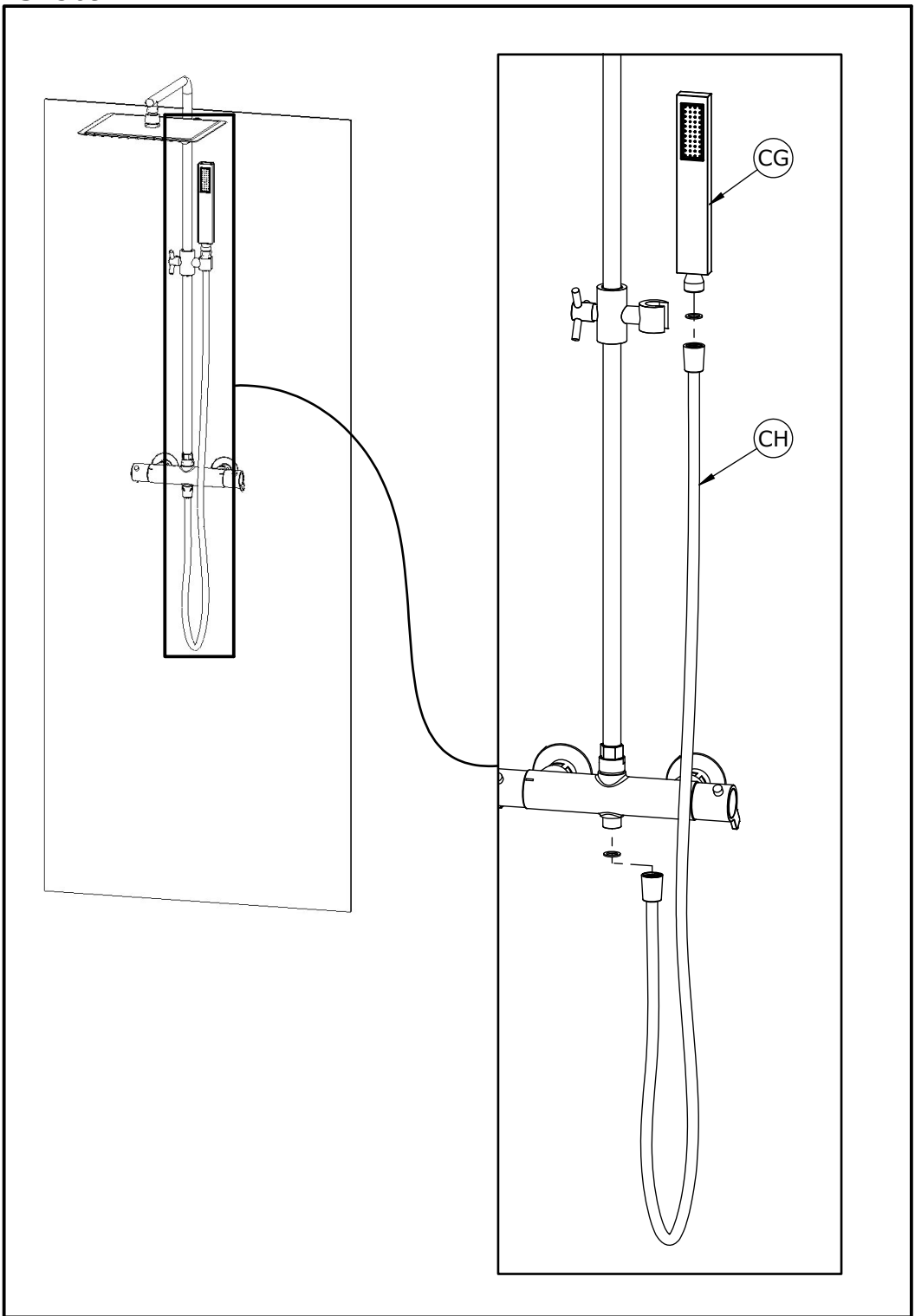



- Version noire ● Black version
- Versión negra ● Versione nera
- Zwarte versie ● Schwarze Version

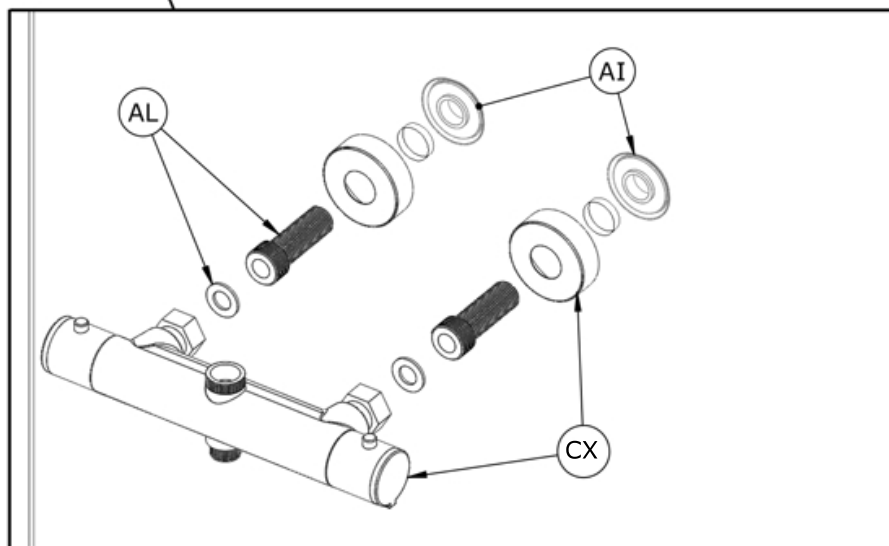
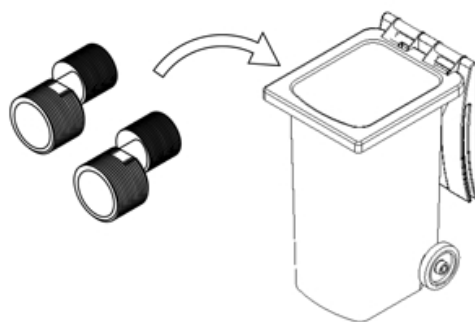
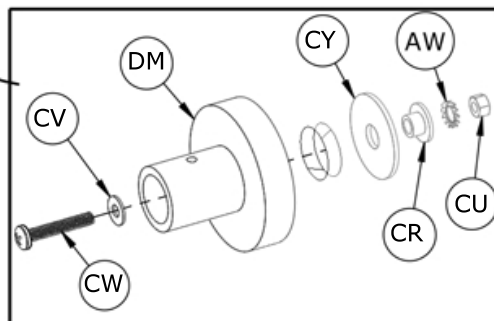



- F Version noire ● GB Black version
- E Versión negra ● I Versione nera
- NL Zwarte versie ● D Schwarze Version

- F Sérigraphie à l'intérieur
- GB Screen printing on the inside
- E Impresión interior
- I Serigrafia interna
- NL Decorglas aan de binnenzijde
- D Siebdruck innen

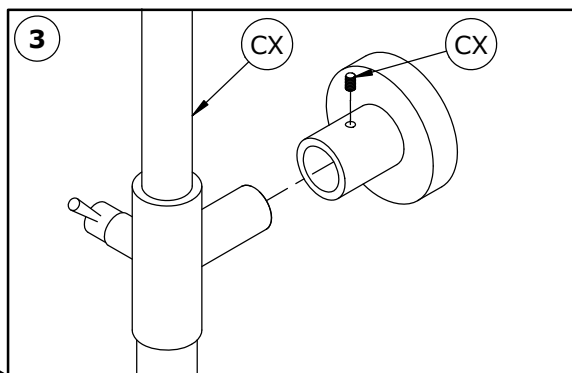
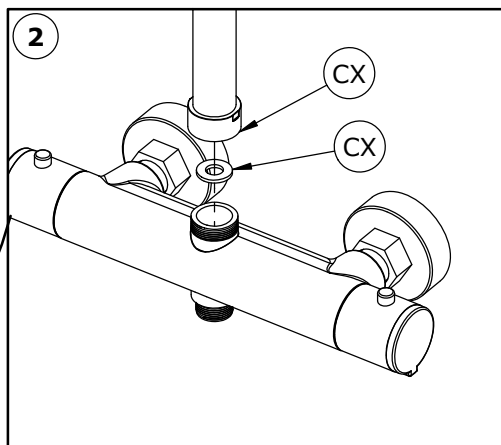
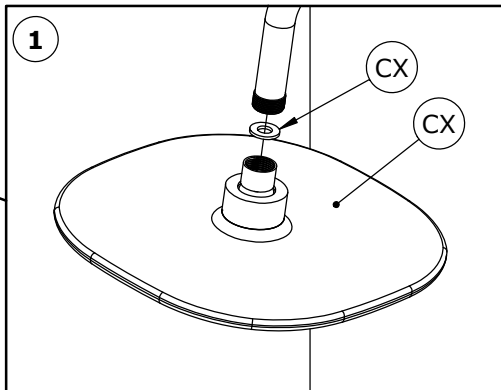



- F Version noire ● GB Black version
● E Versión negra ● I Versione nera
● NL Zwarte versie ● D Schwarze Version

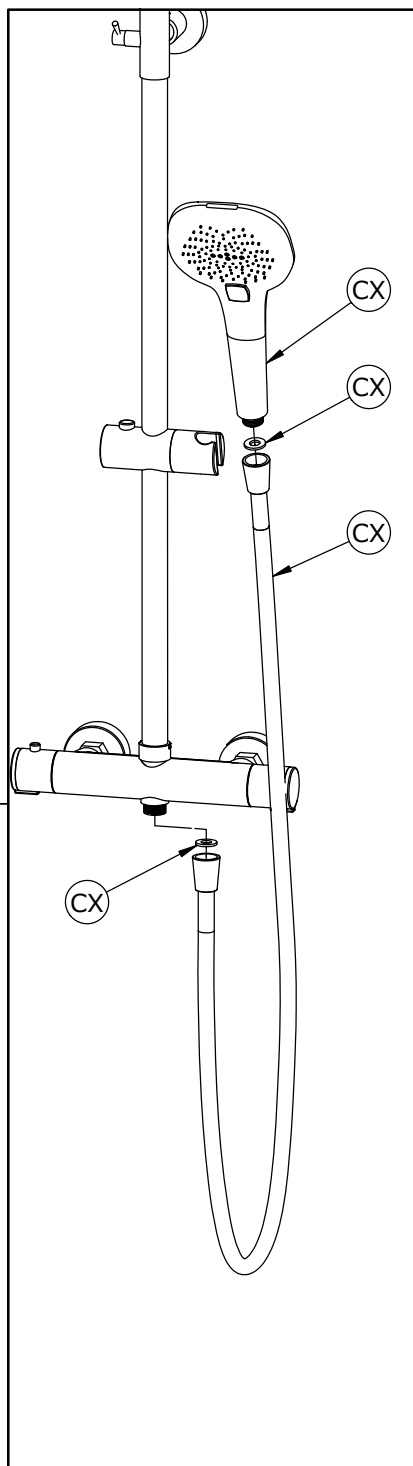
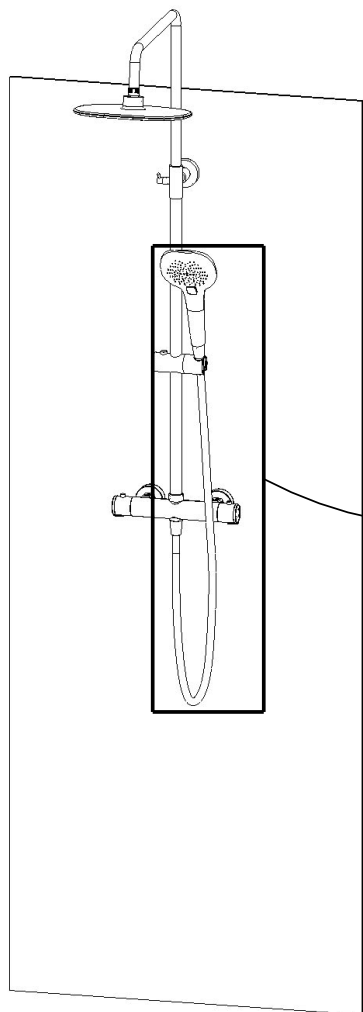

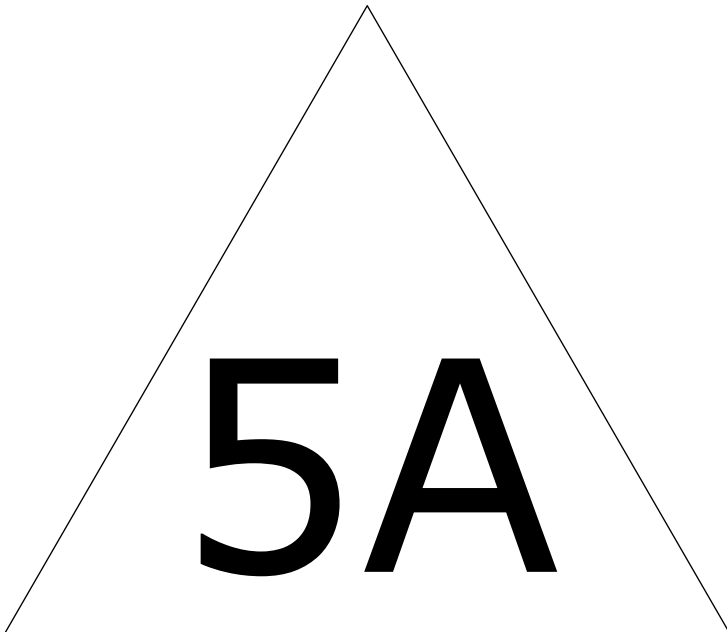
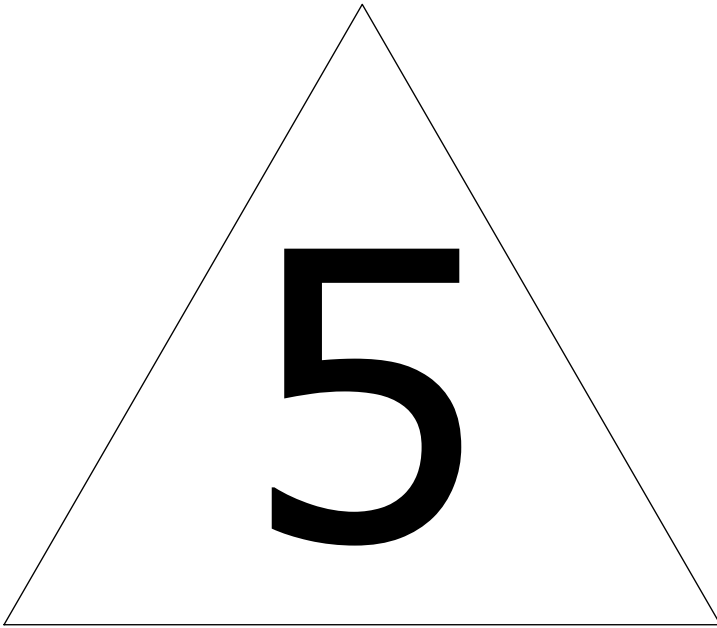

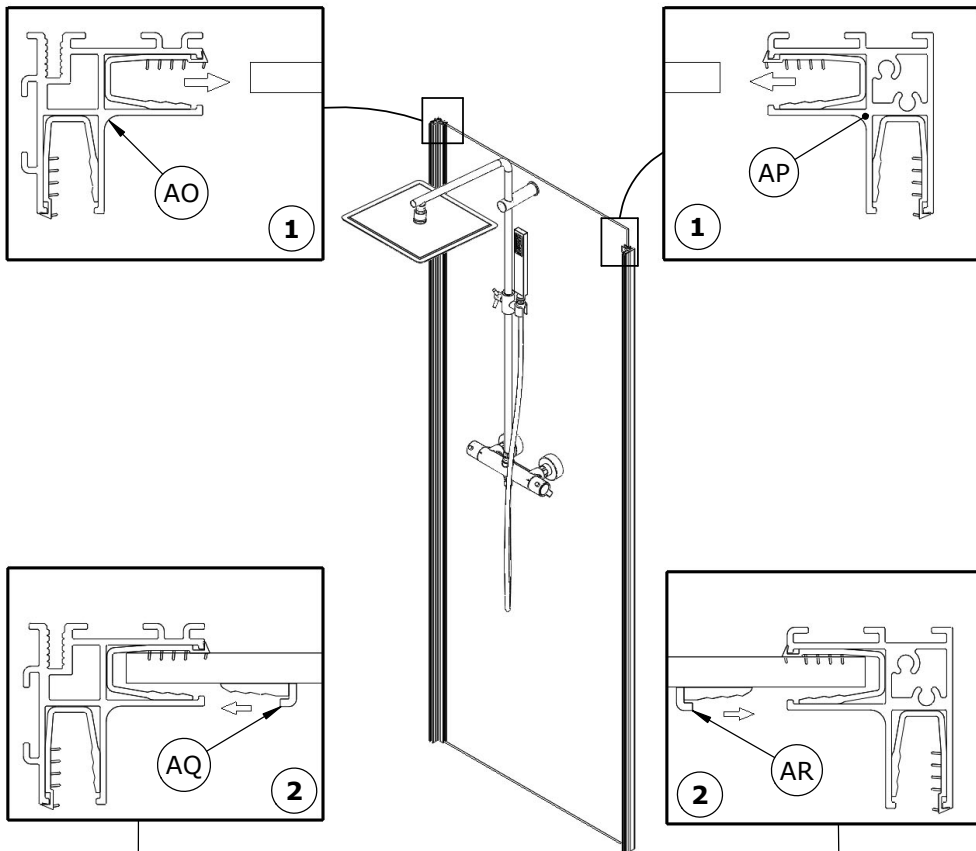

- F** Zone de réglage - Ne pas verrouiller **GB** Setting zone - Do not lock
E Zona de ajuste - No bloquear **I** Zona di regolazione - Non bloccare
NL Afstel zone - Niet vast zetten **D** Einstellbereich - Nicht blockieren

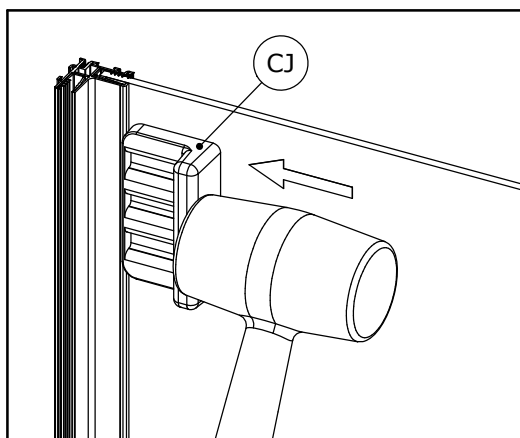

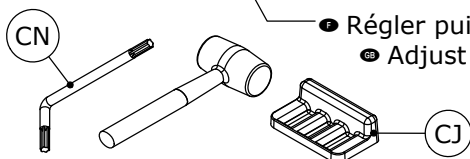
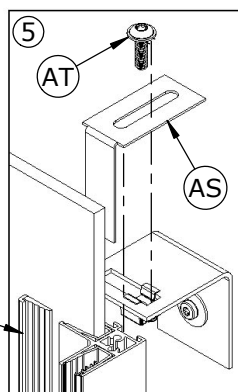
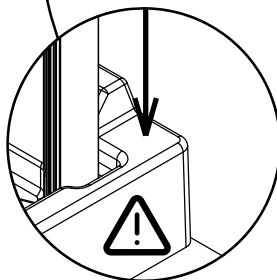
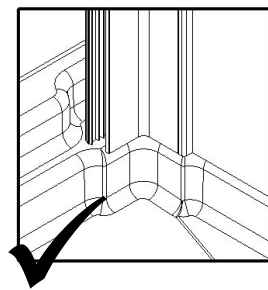
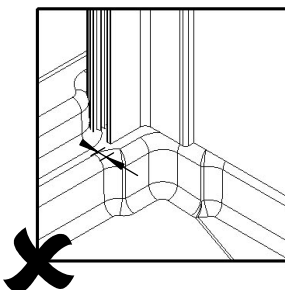
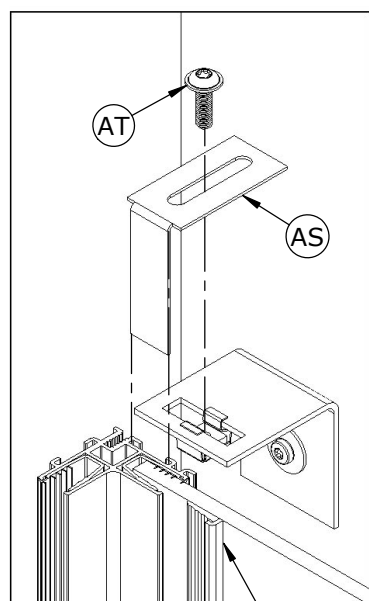
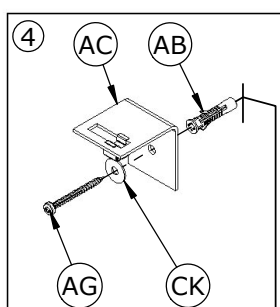
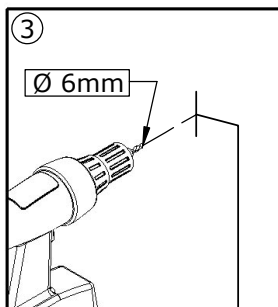
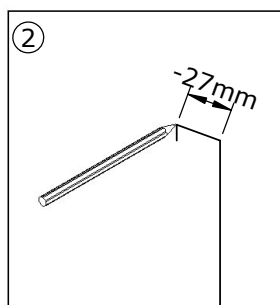
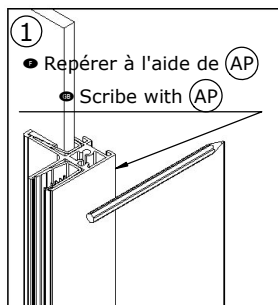
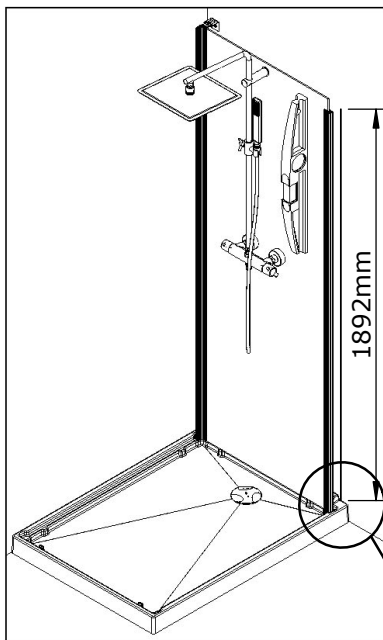

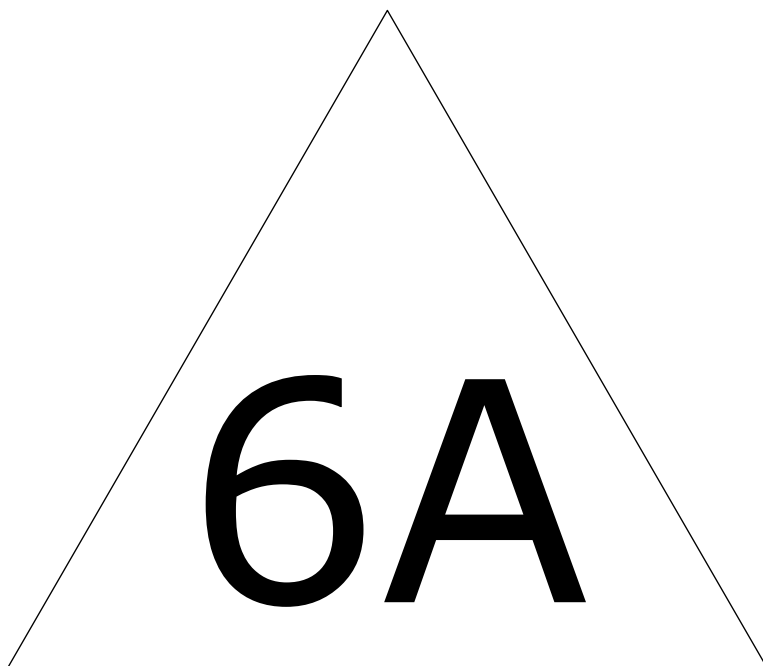
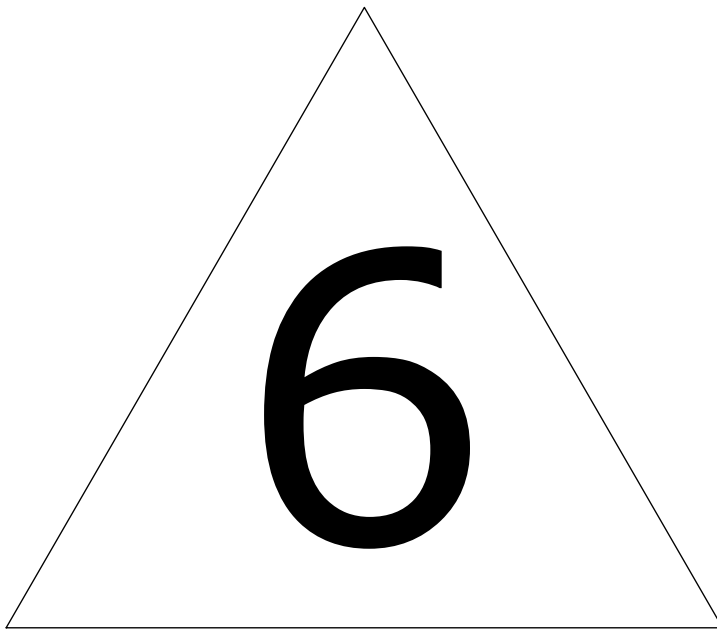

- Sérigraphie à l'extérieur
- Screen printing on the outside
- Impresión en el fuera
- Serigrafía esterna
- Glas-print aan buitenzijde
- Siebdruck außen

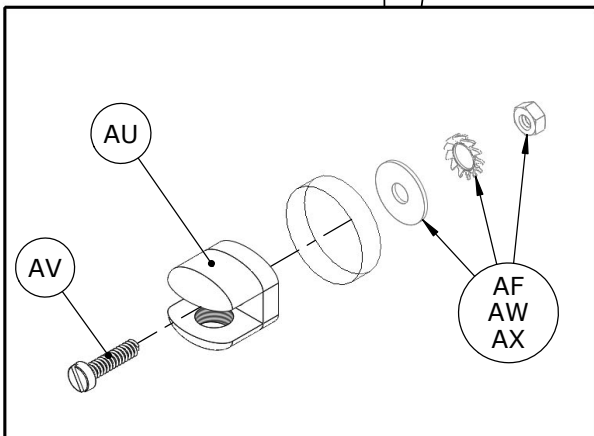
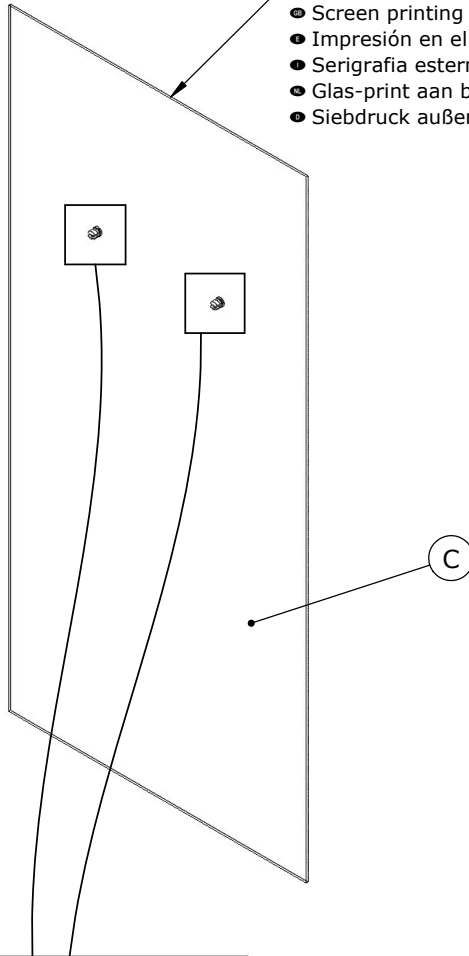

TAILLE 110
TAILLE 120

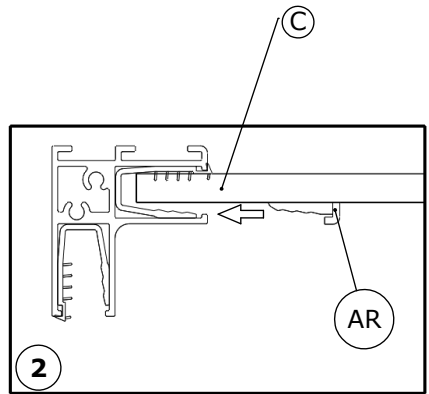
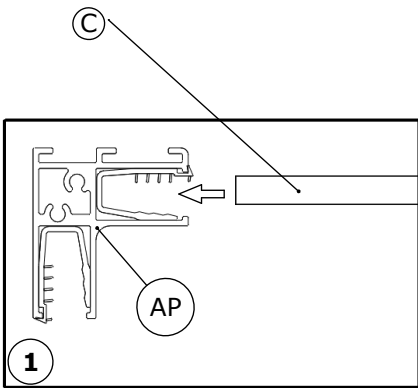
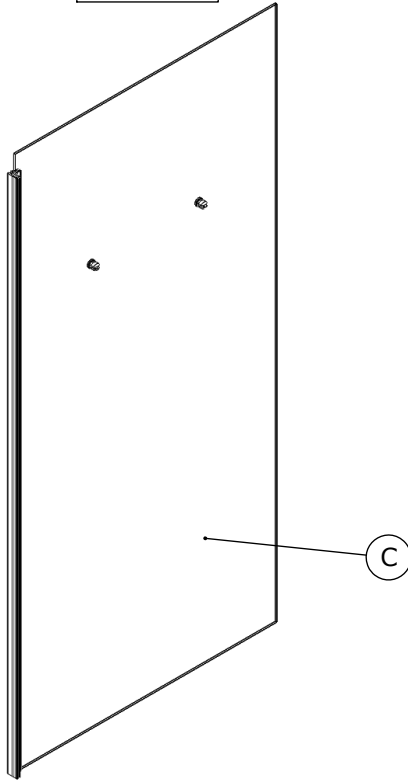

TAILLE 110
TAILLE 120

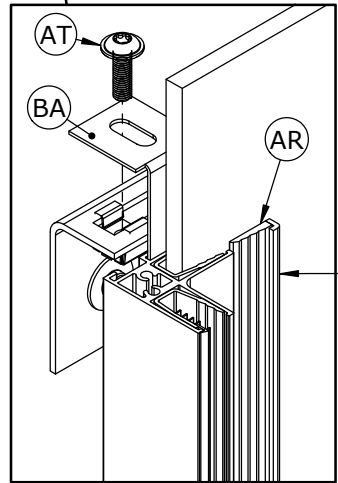
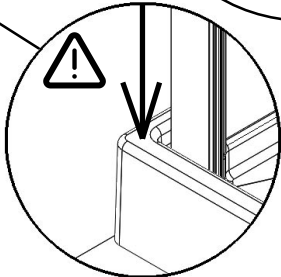
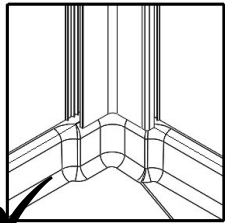
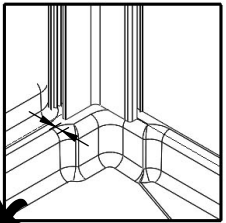
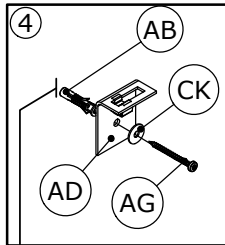
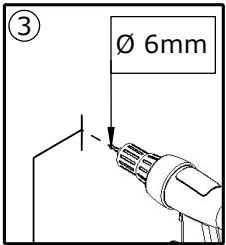
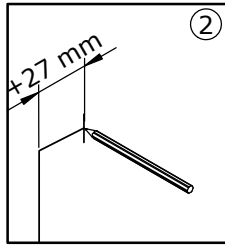
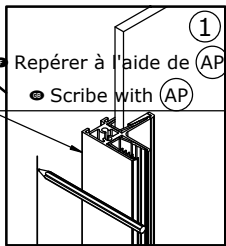
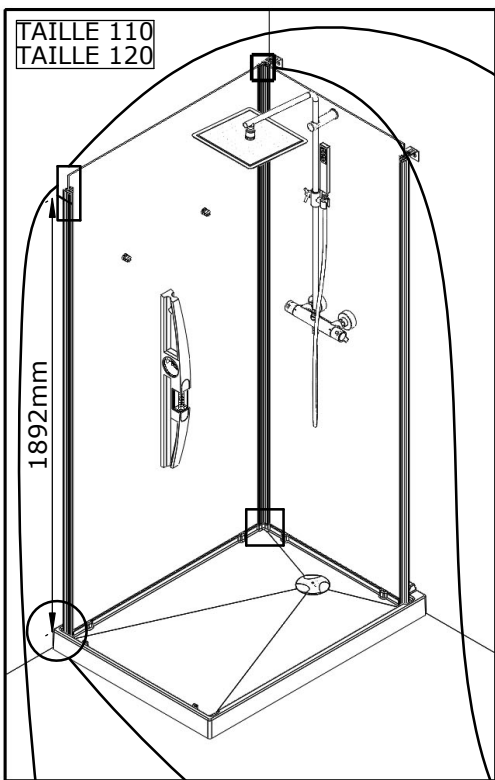

● Régler puis verrouiller
● Adjust and lock

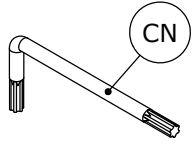
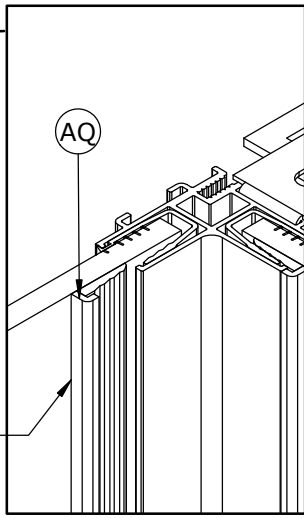

TAILLE 160
TAILLE 170

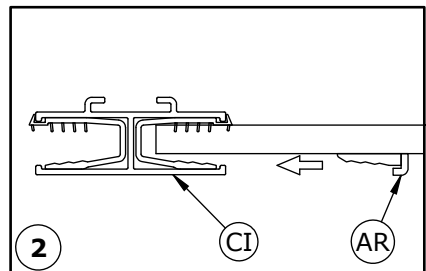
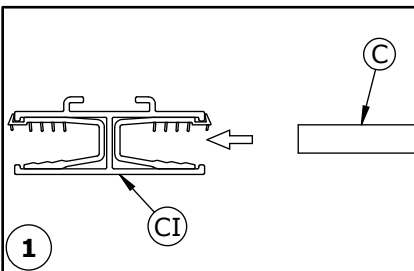
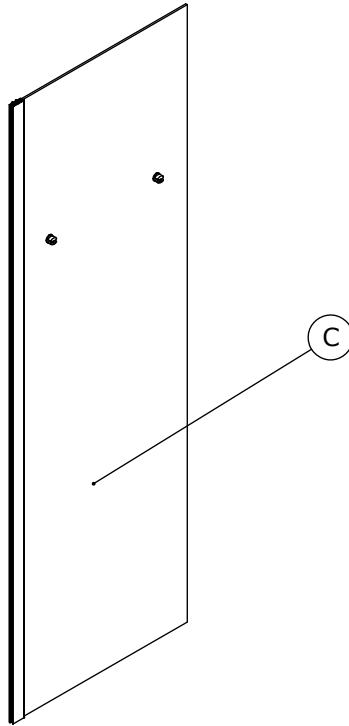

TAILLE 160
TAILLE 170

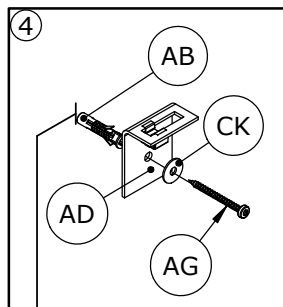
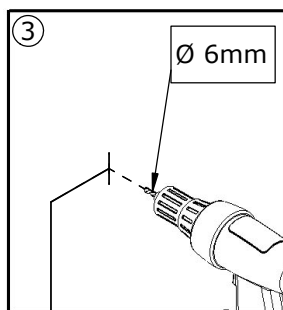
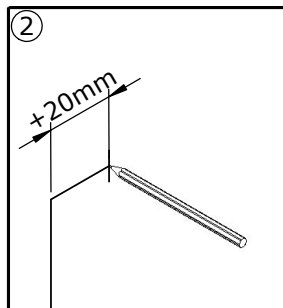
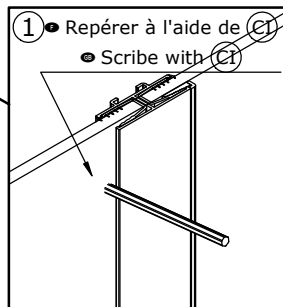
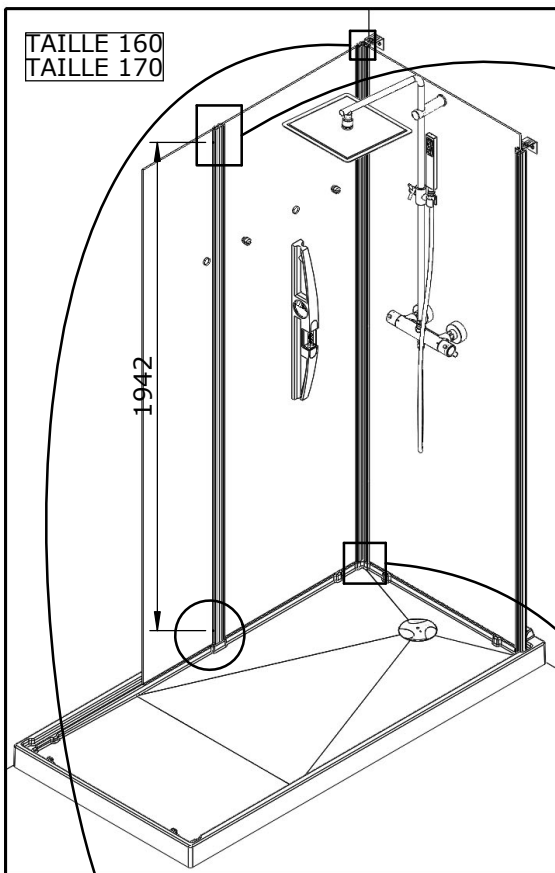

● Régler puis verrouiller
● Adjust and lock

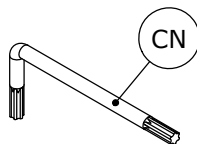
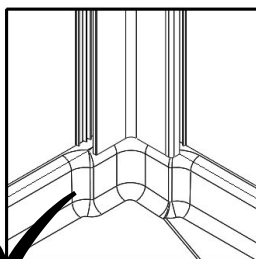
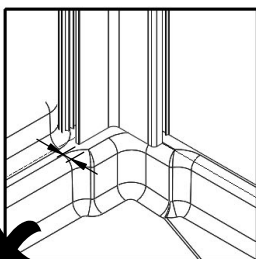
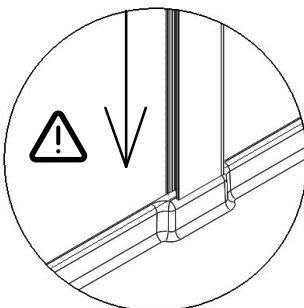
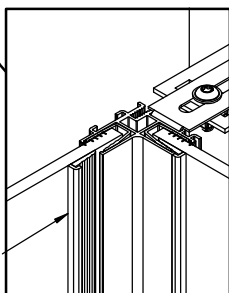

TAILLE 160
TAILLE 170

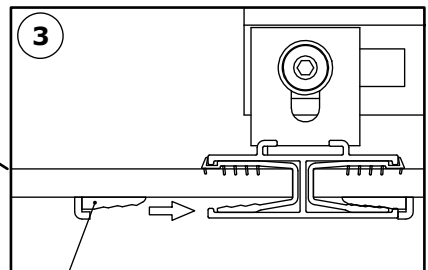
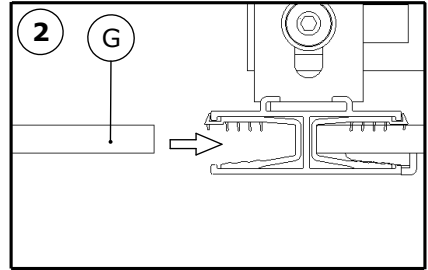
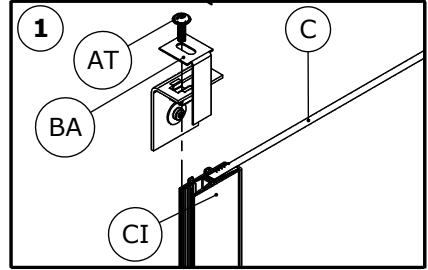
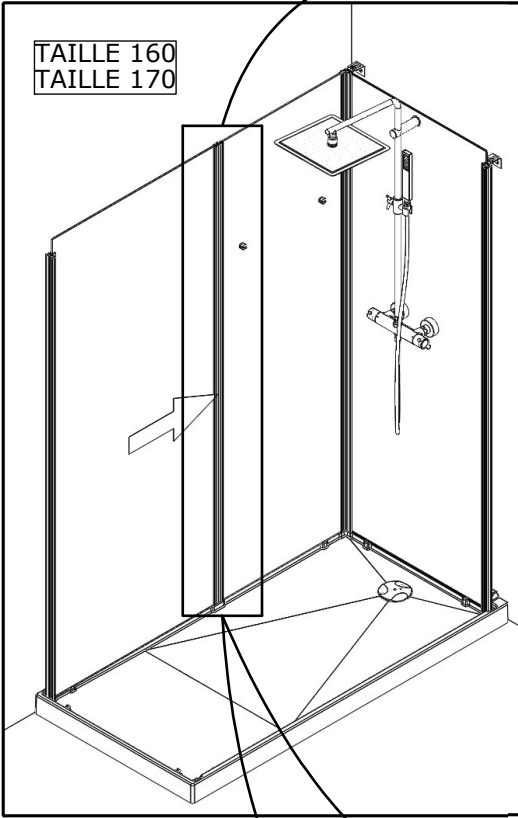

TAILLE 160
TAILLE 170

1892mm

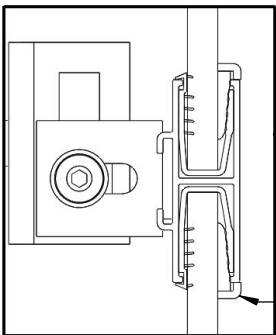
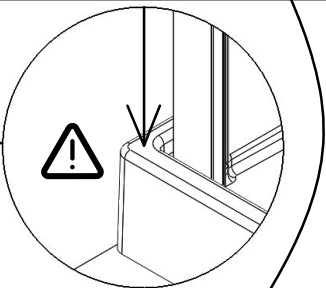
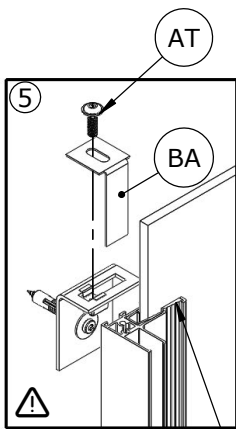
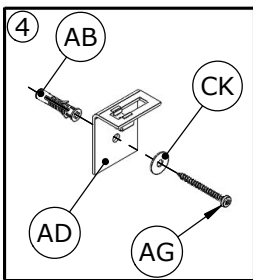
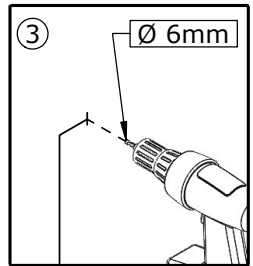
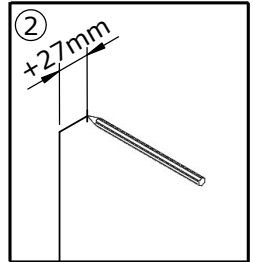
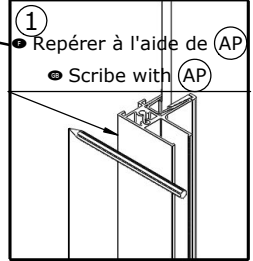

Ⓕ Régler puis verrouiller
ⒼⒽ Adjust and lock

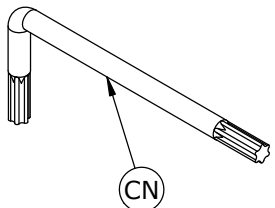

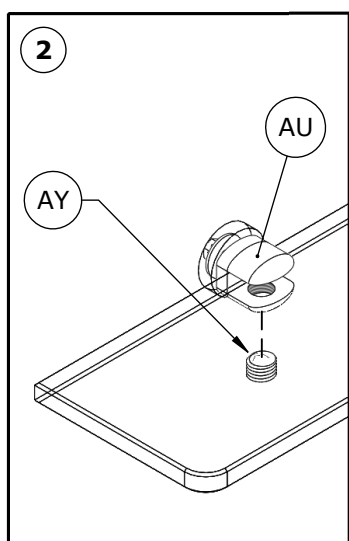
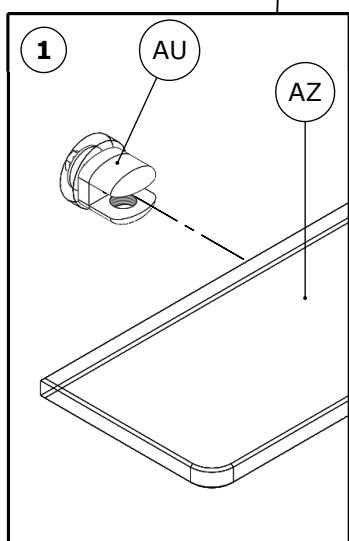
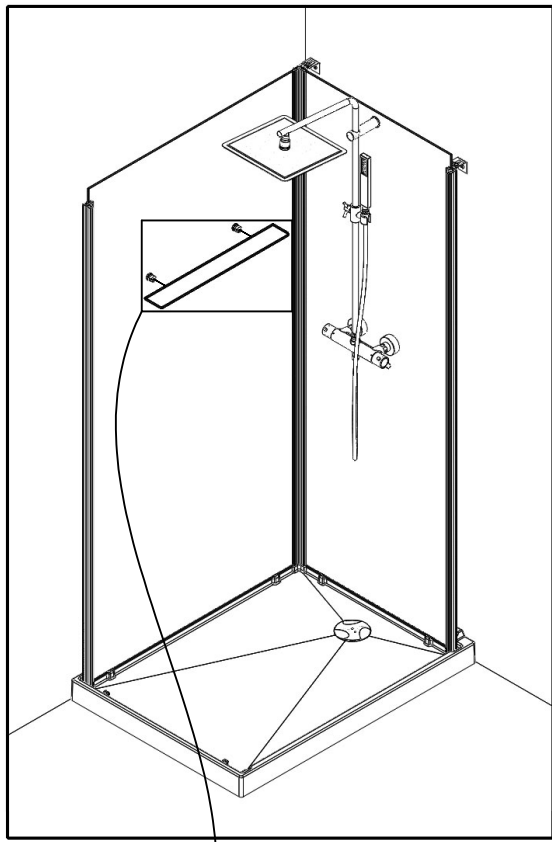

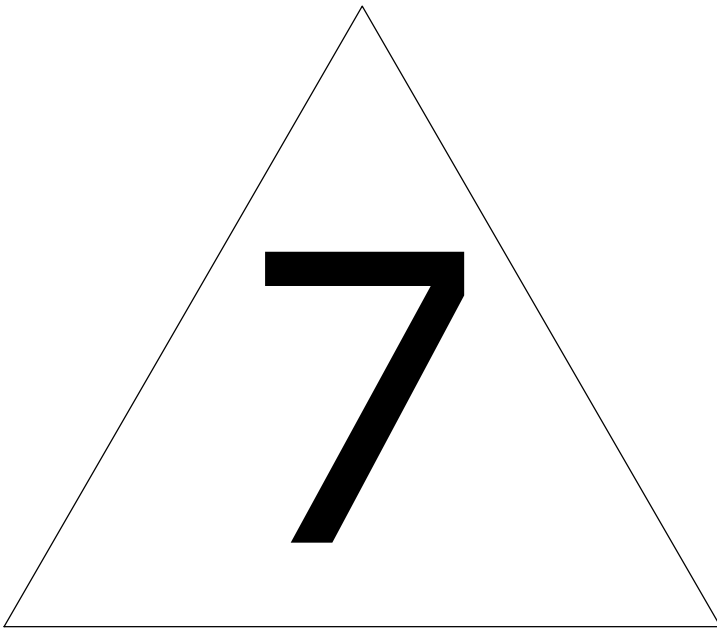

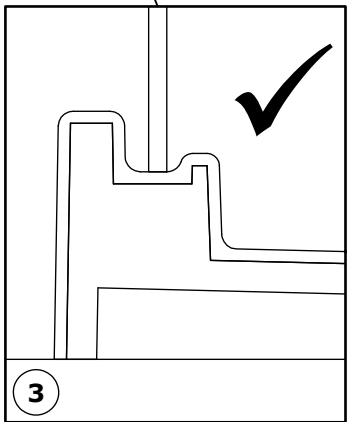
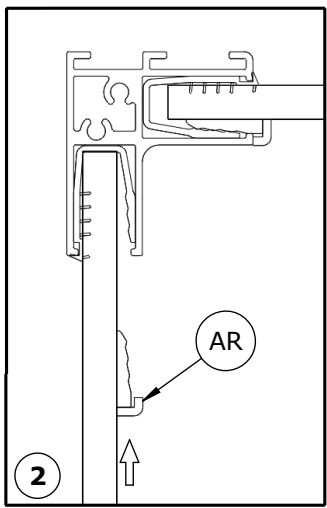
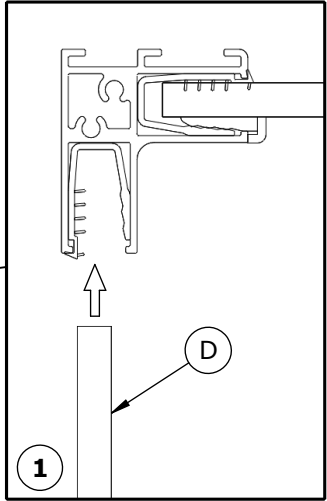
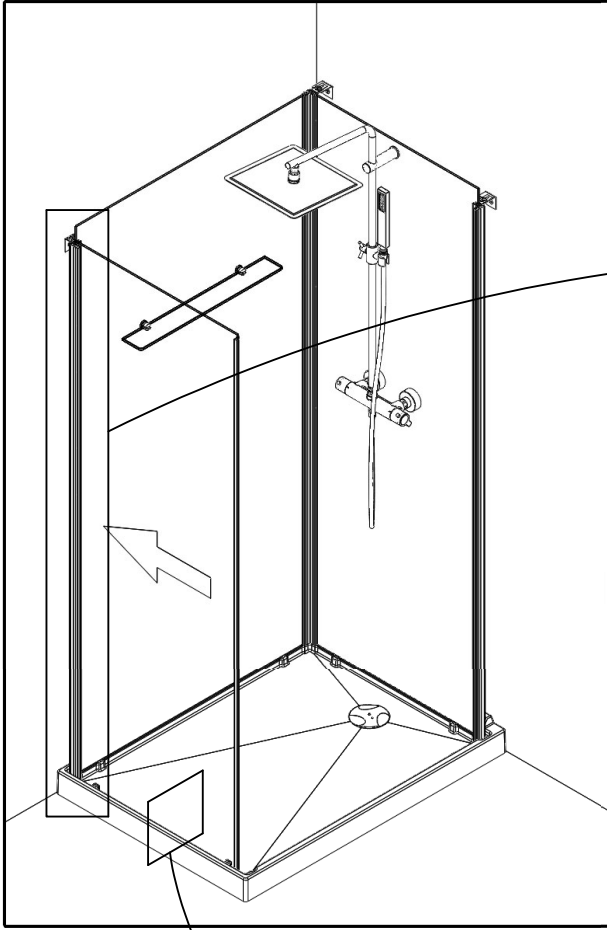

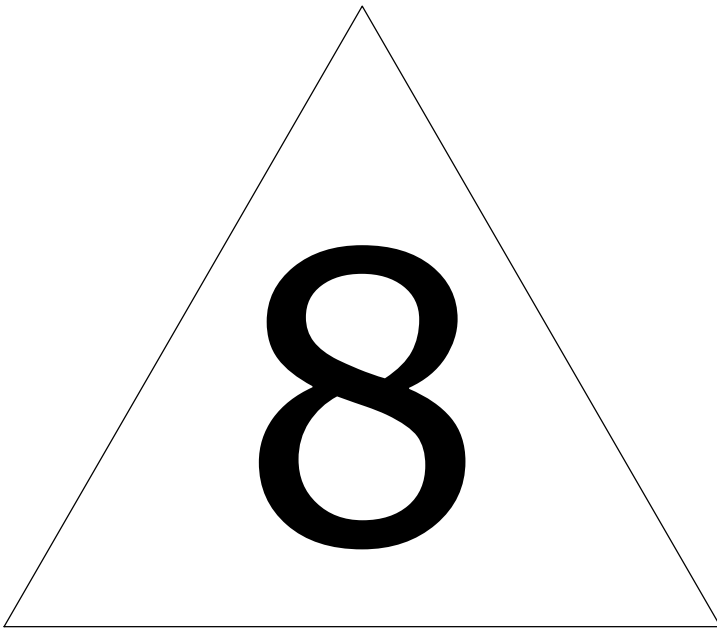

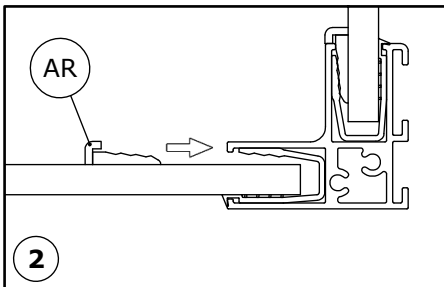
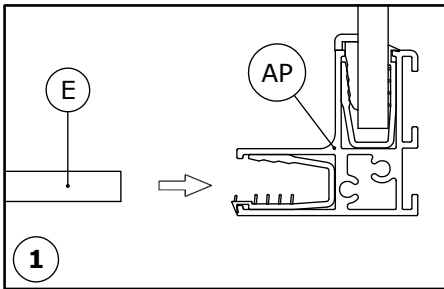
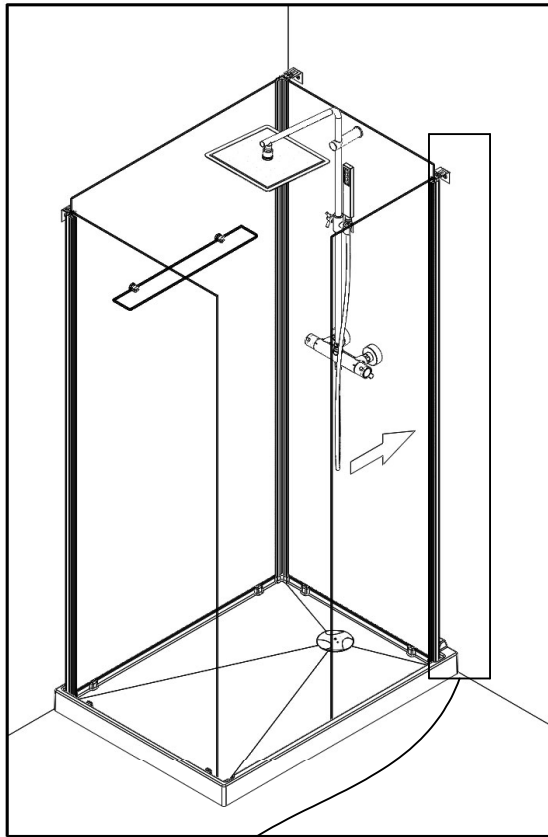

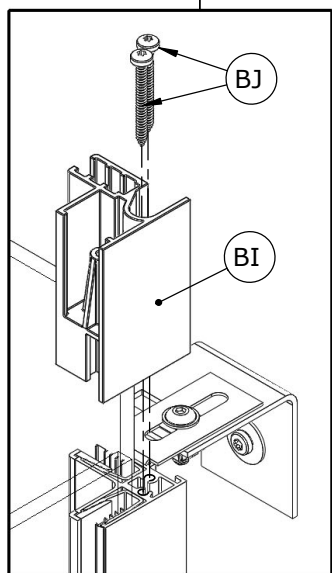
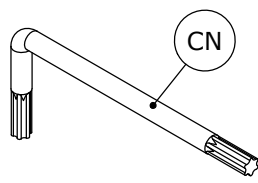
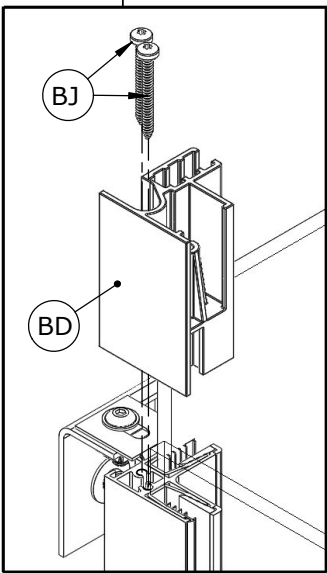
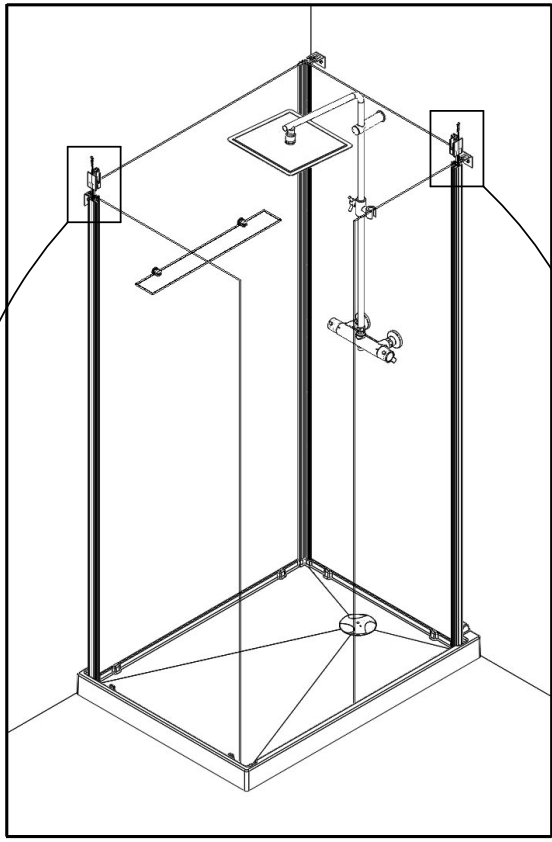

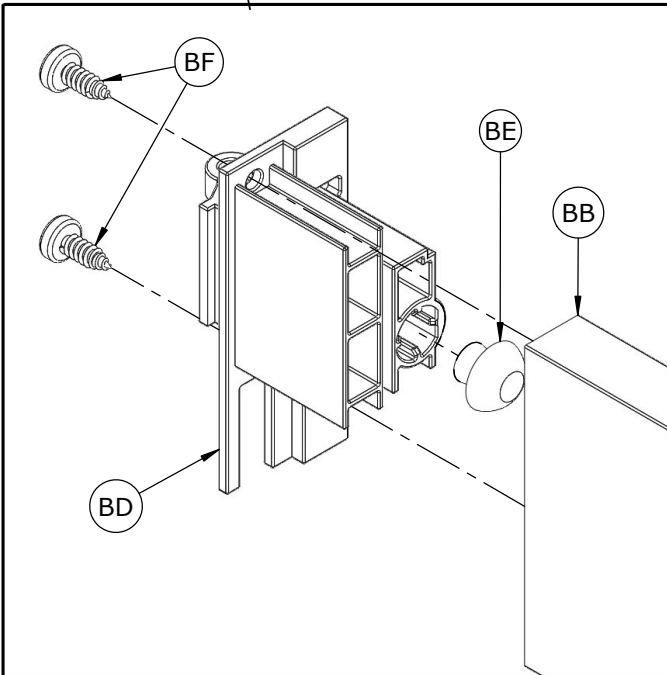
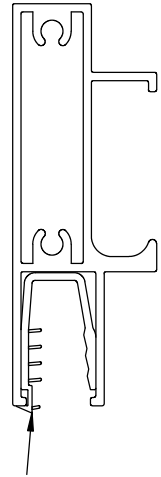
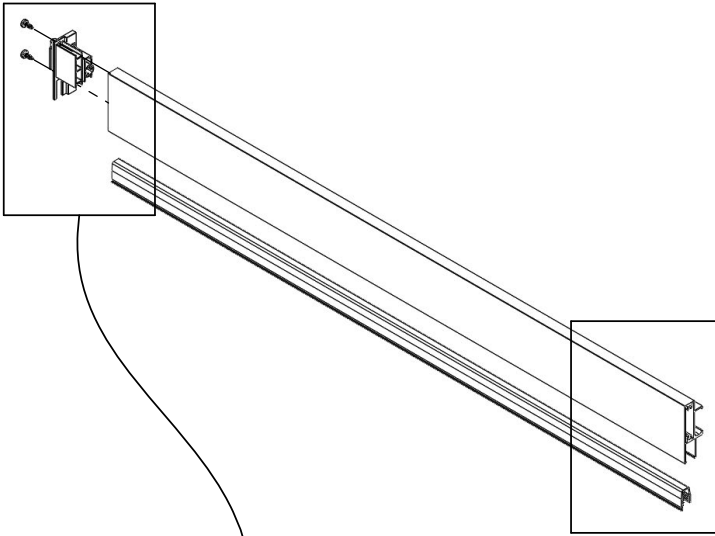

- Attention :
Sens de montage
- ⚠ Warning :
Mounting direction
- Atención :
Dirección de montaje
- Attenzione :
Direzione di montaggio
- Waarschuwing :
Montagerichting
- Achtung :
Montagerichtung

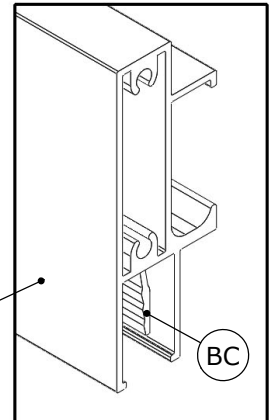
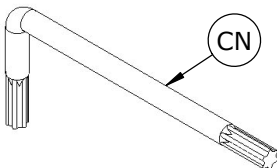

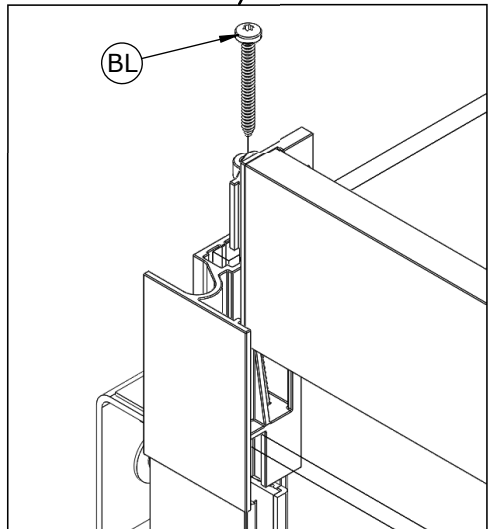
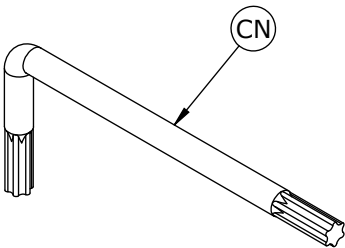
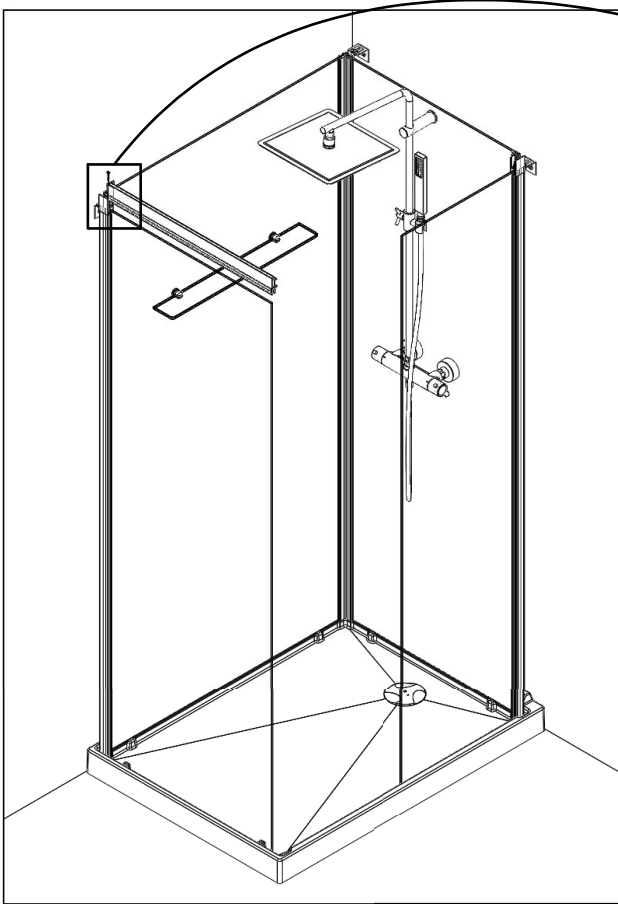

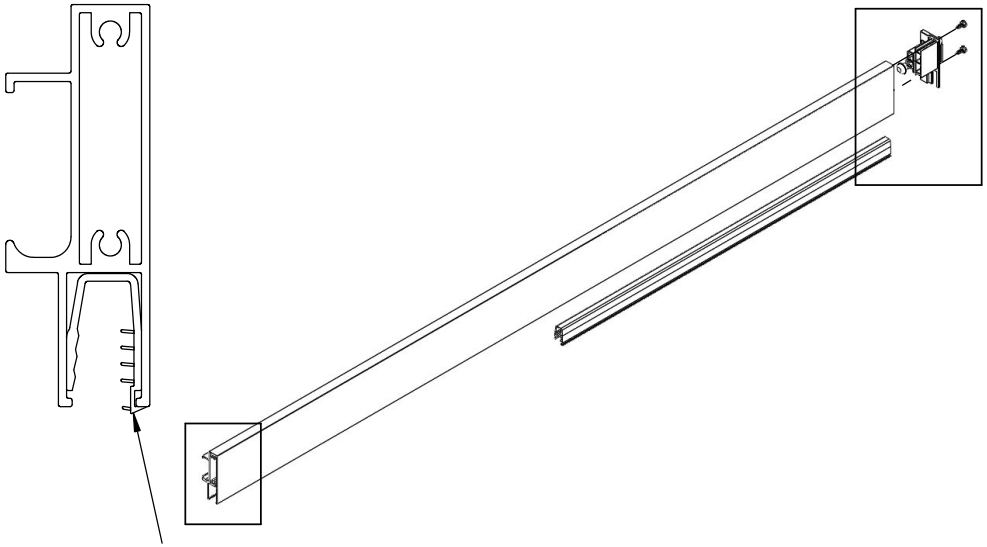

- Attention :
Sens de montage
- ⚠ Warning :
Mounting direction
- Atención :
Dirección de montaje
- Attenzione :
Direzione di montaggio
- ⚠ Waarschuwing :
Montagerichting
- Achtung :
Montagerichtung

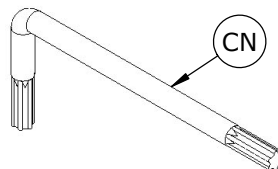
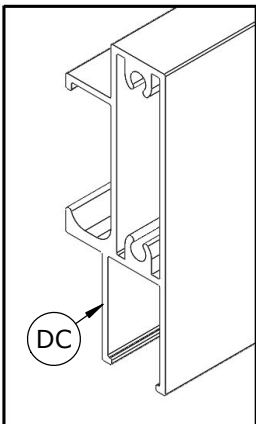
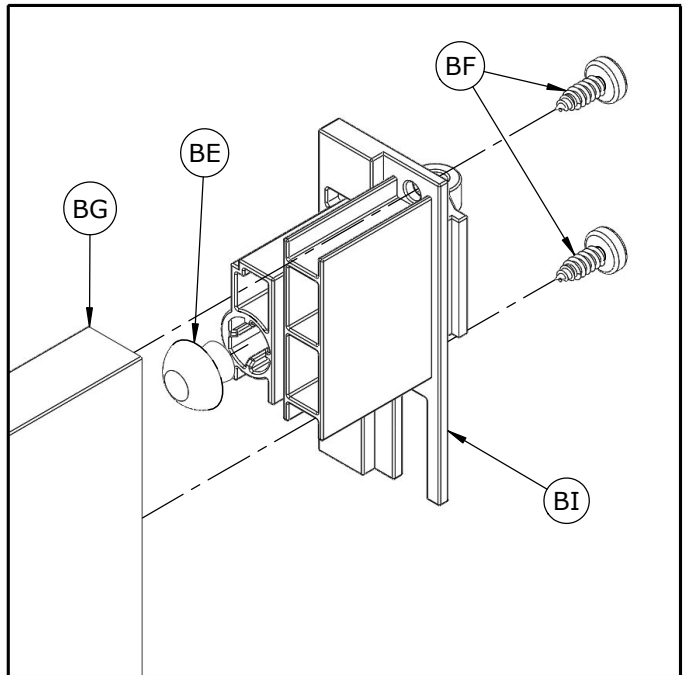

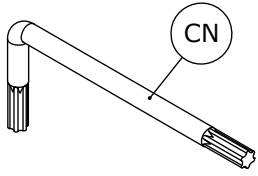
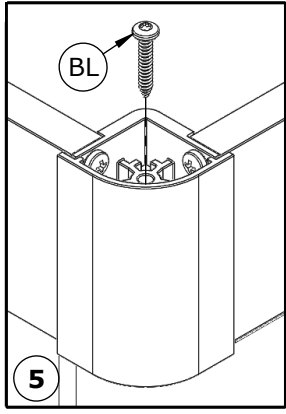
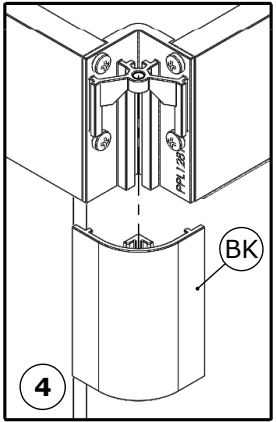
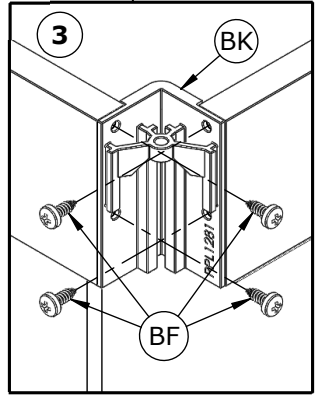
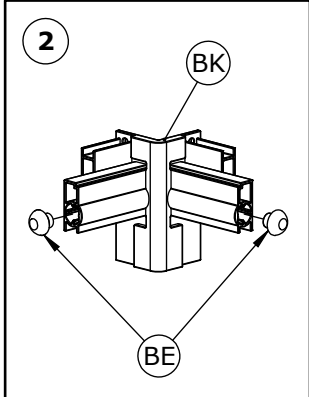
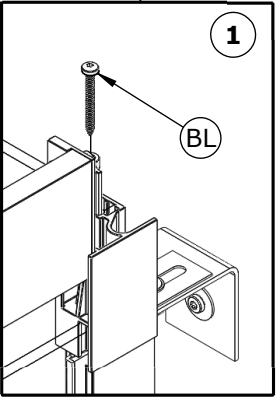
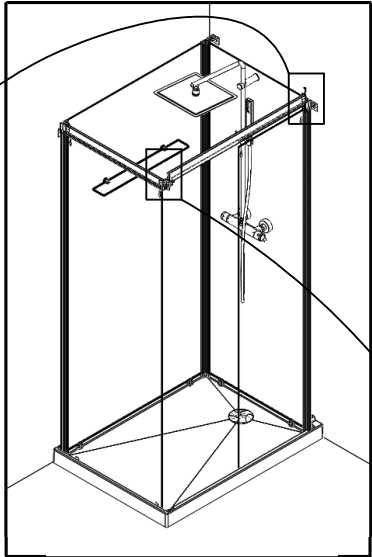

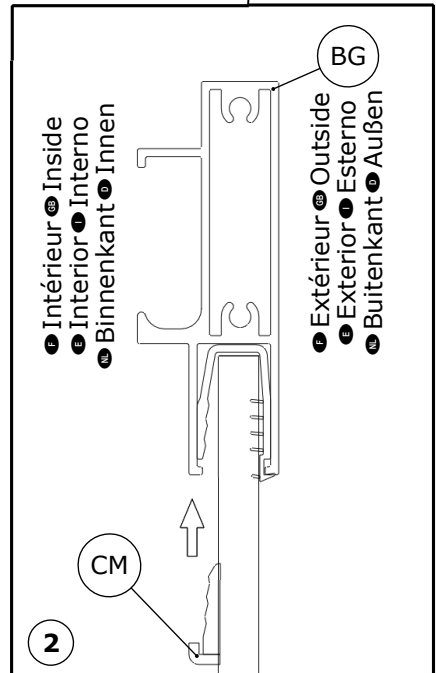
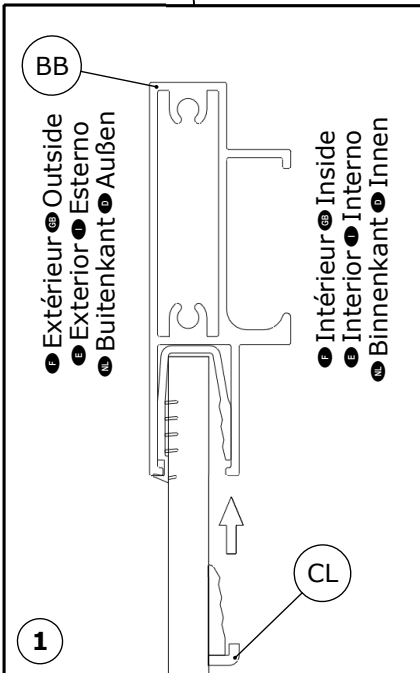
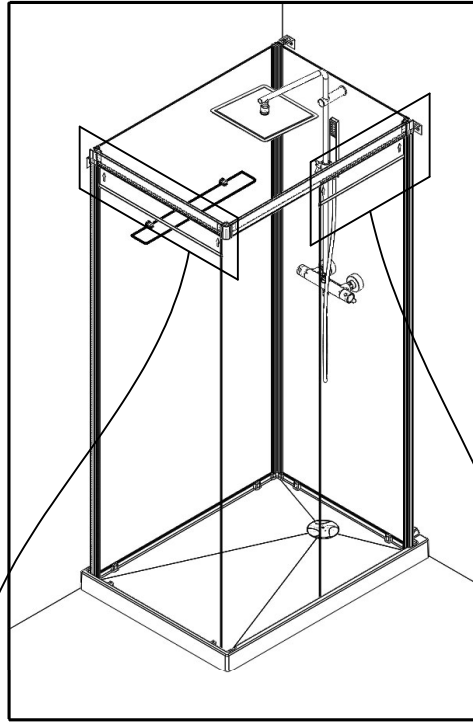

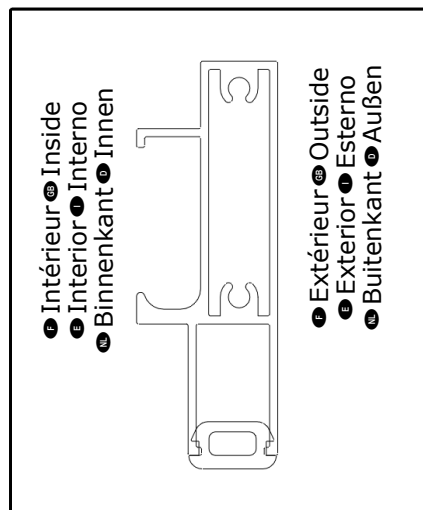
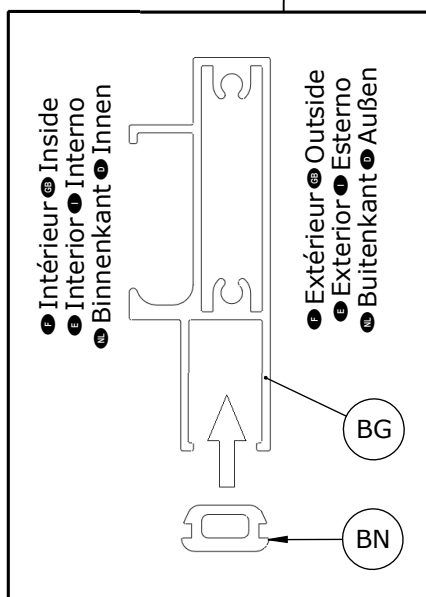
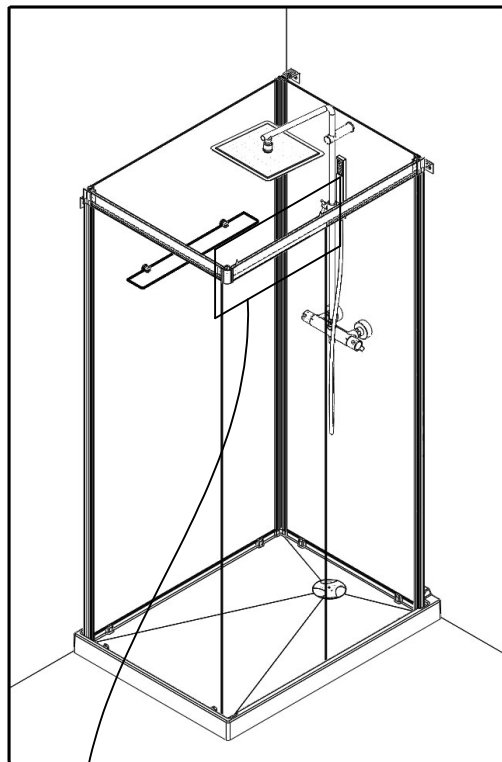

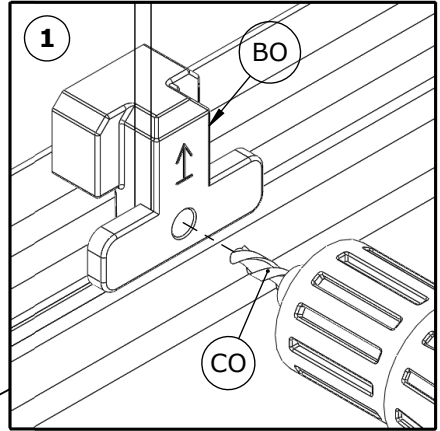
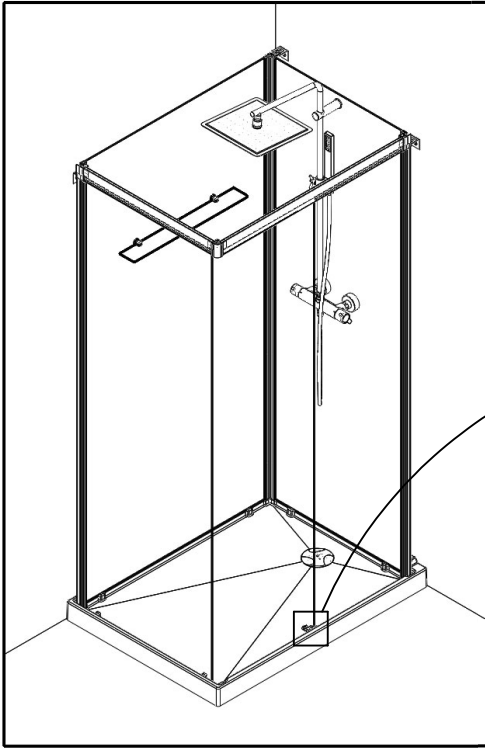

• Vue intérieur • Interior view • Vista interior
• Vista interna • Binnen aanzicht • Innenansicht

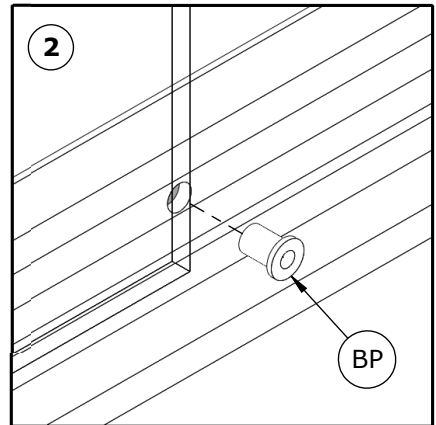

• Vue intérieur • Interior view • Vista interior
• Vista interna • Binnen aanzicht • Innenansicht

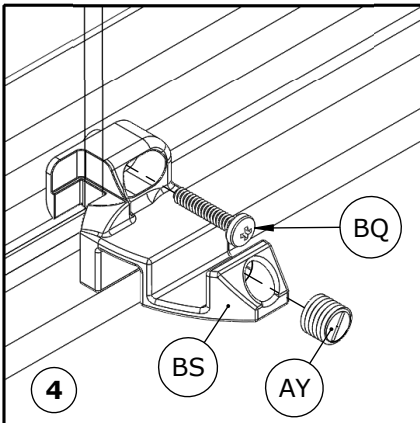
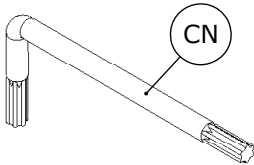

• Vue intérieur • Interior view • Vista interior
• Vista interna • Binnen aanzicht • Innenansicht

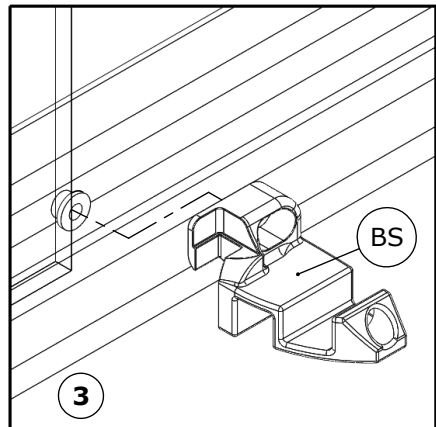

• Vue intérieur • Interior view • Vista interior
• Vista interna • Binnen aanzicht • Innenansicht

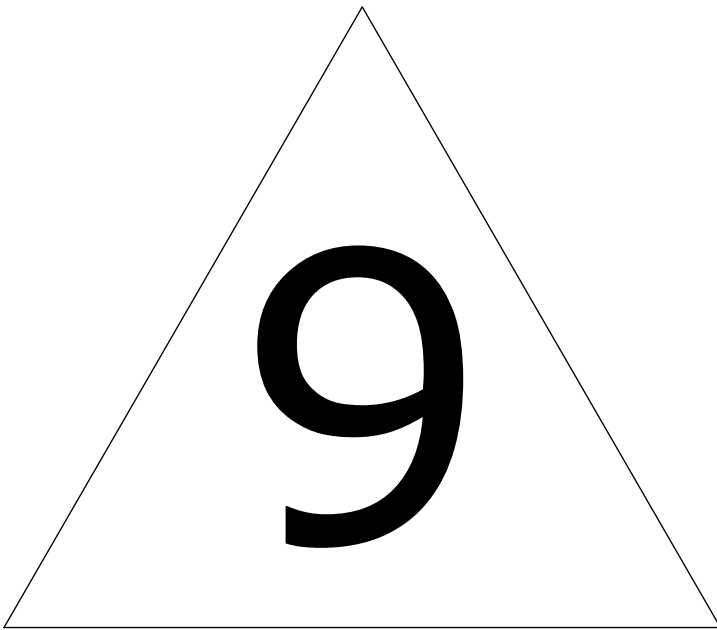

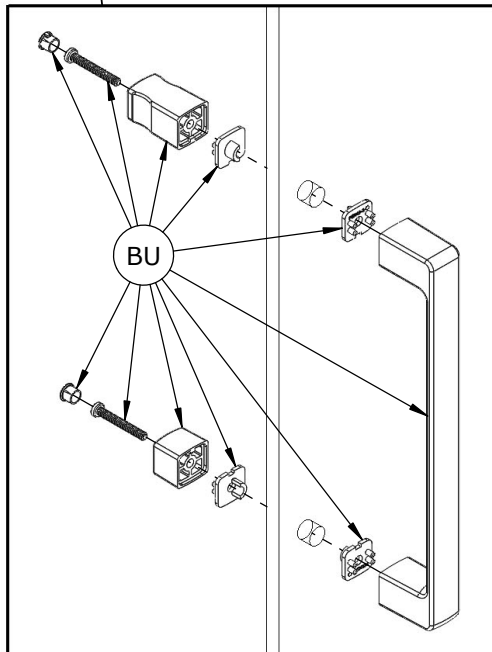
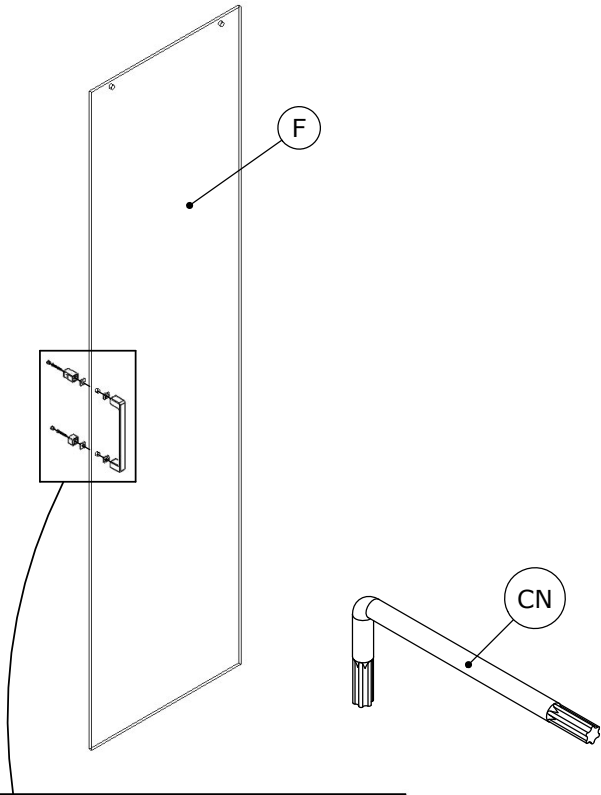

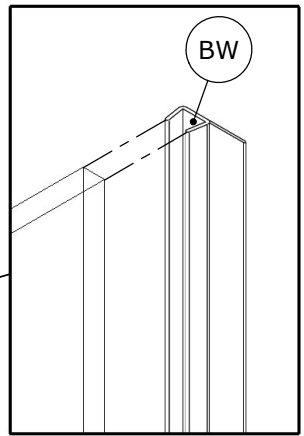
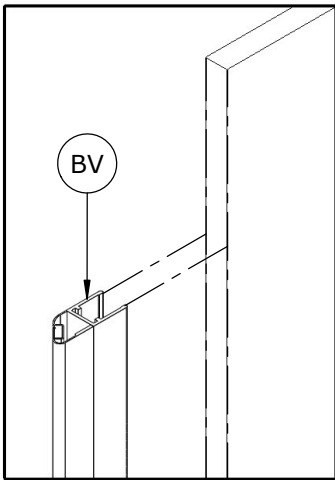

- Intérieur ● Inside
- Interior ● Interno
- Binnenkant ● Innen

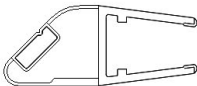

- Extérieur ● Outside
- Exterior ● Esterno
- Buitenkant ● Außen

- Intérieur ● Inside
- Interior ● Interno
- Binnenkant ● Innen

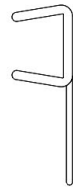

- Extérieur ● Outside
- Exterior ● Esterno
- Buitenkant ● Außen

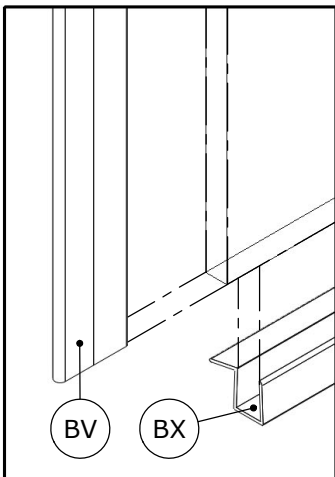

- Intérieur ● Interior
- Interno ● Binnenkant ● Innen

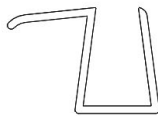

- Extérieur ● Exterior
- Esterno ● Buitenkant ● Außen

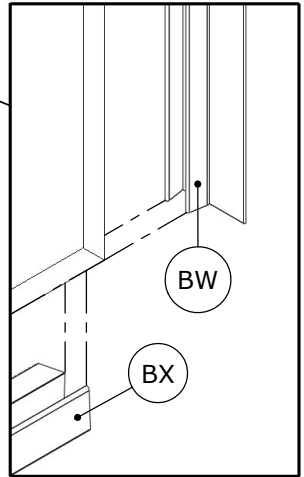

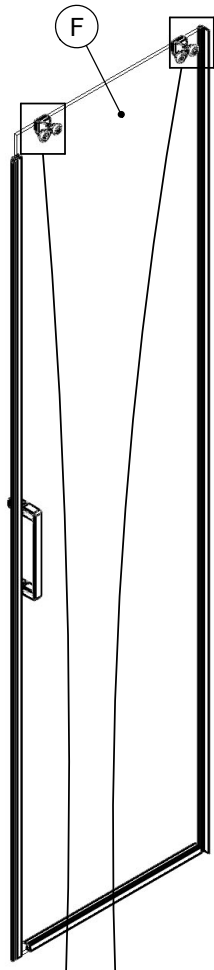

T110 - T120 X2
T160 - T170 X3

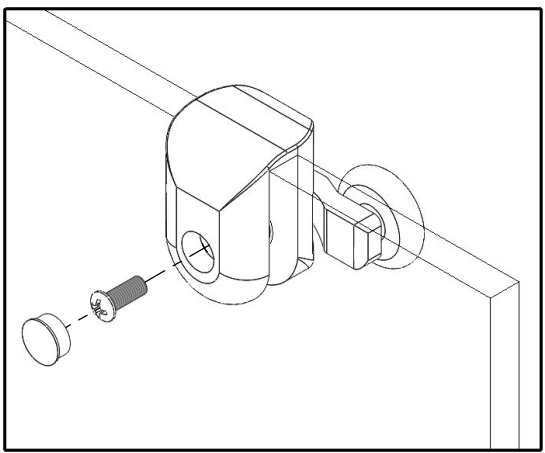
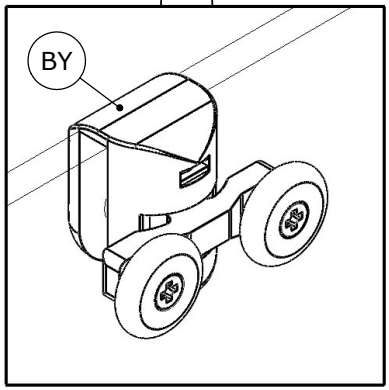
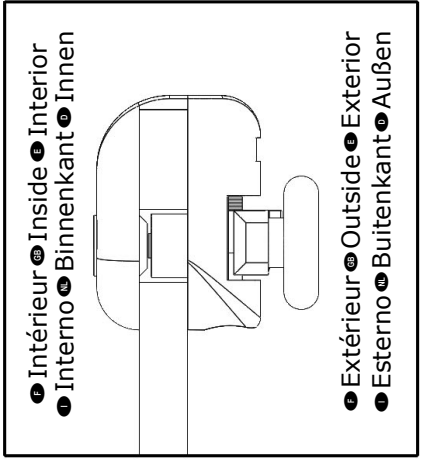

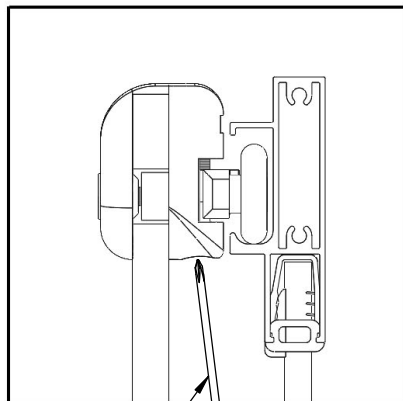
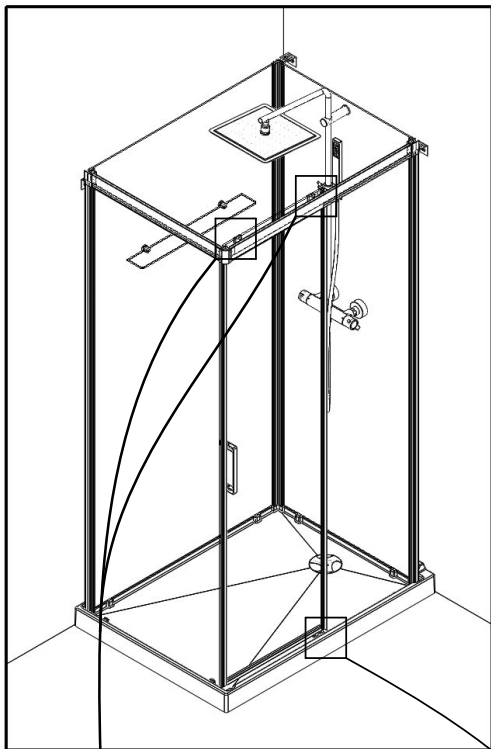

- Réglage des portes
- Doors adjustment
- Ajuste de las puertas
- Regolazione porte
- Deuren afstellen
- Ausrichten und Einstellen der Tür

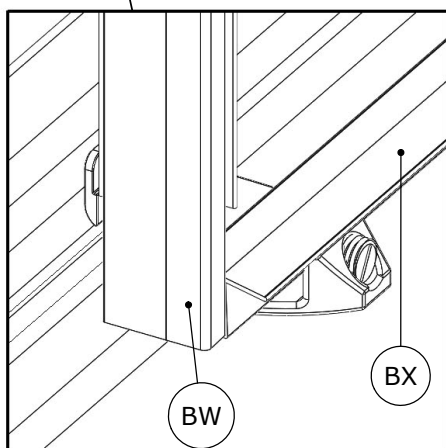
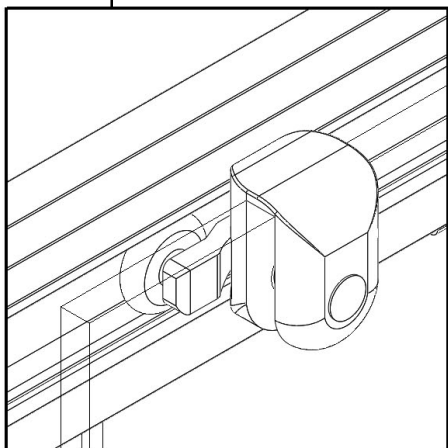

- Vue intérieure ● Interior view ● Vista interior
- Vista inferiore ● Binnenkant ● Innenansicht
- Vue intérieure ● Interior view ● Vista interior
- Vista inferiore ● Binnenkant ● Innenansicht

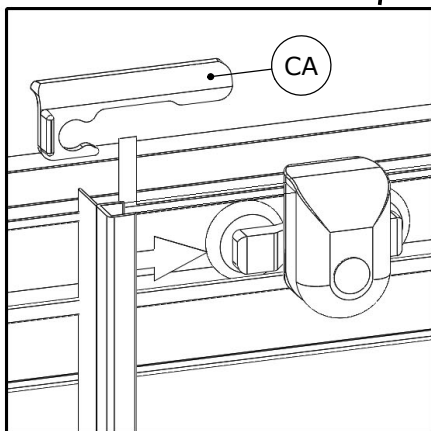
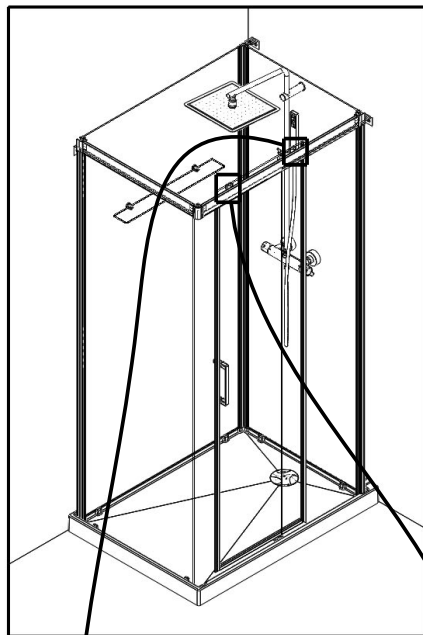

④ Vue intérieure ④ Interior view
 ④ Vista interior ④ Vista inferiore
 ④ Binnenkant ④ Innenansicht

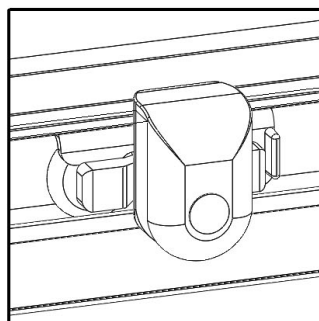
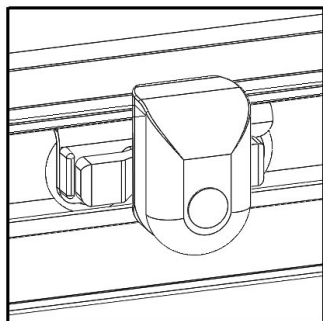
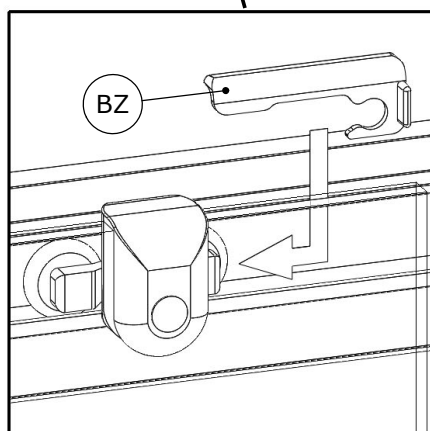

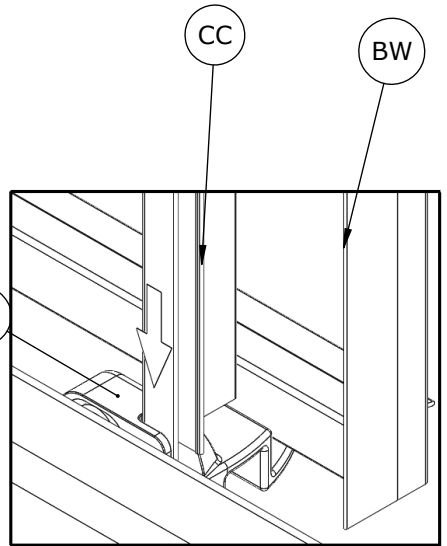
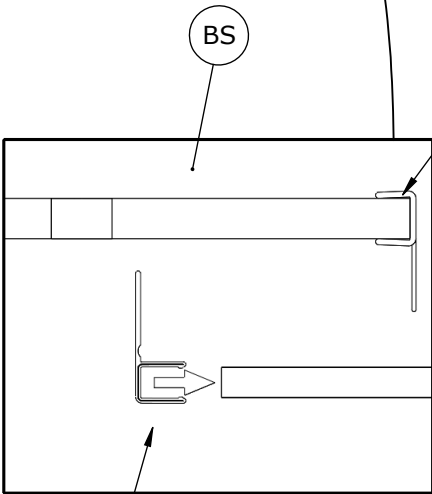
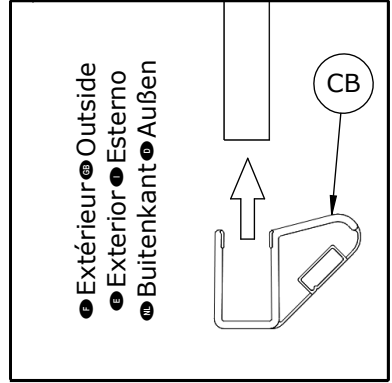
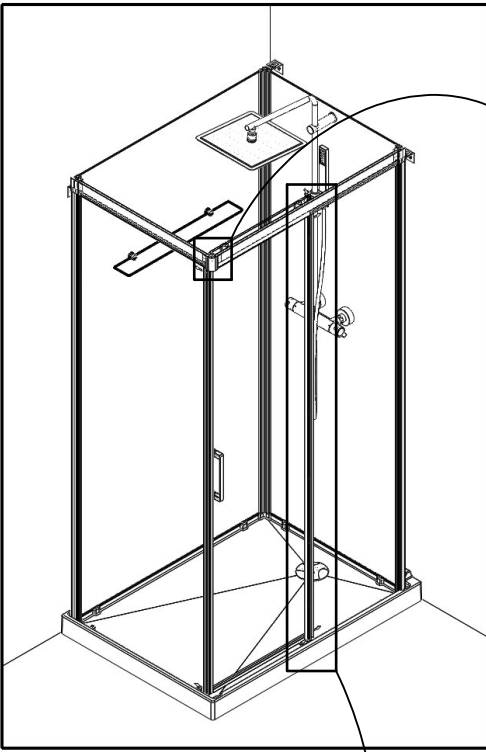

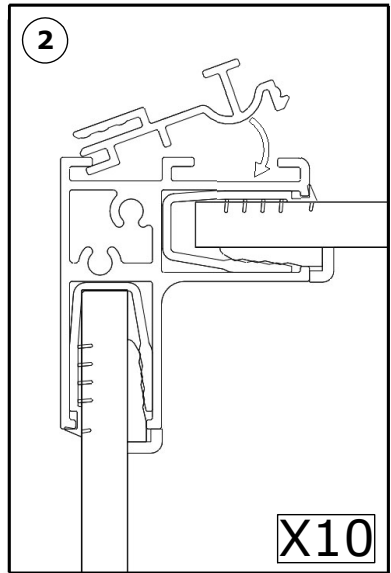
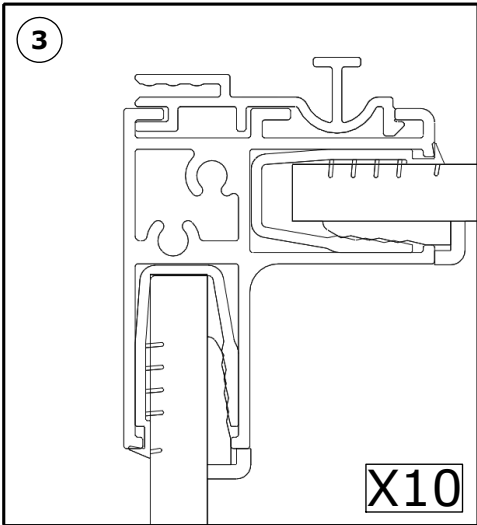
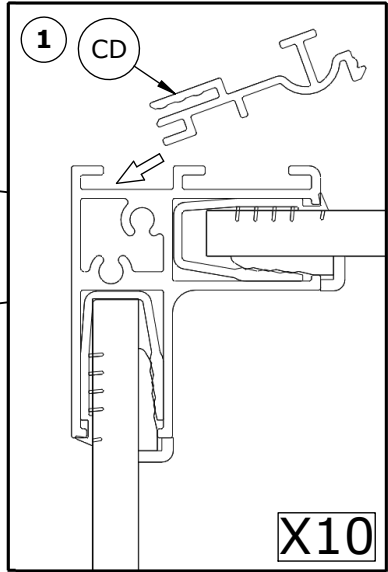
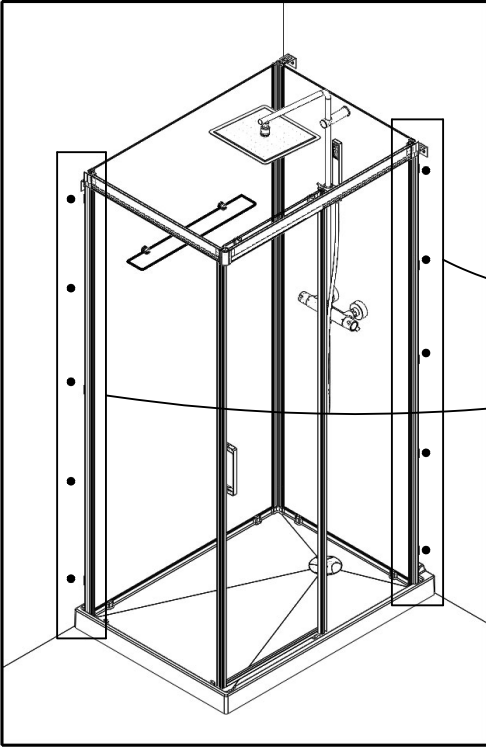

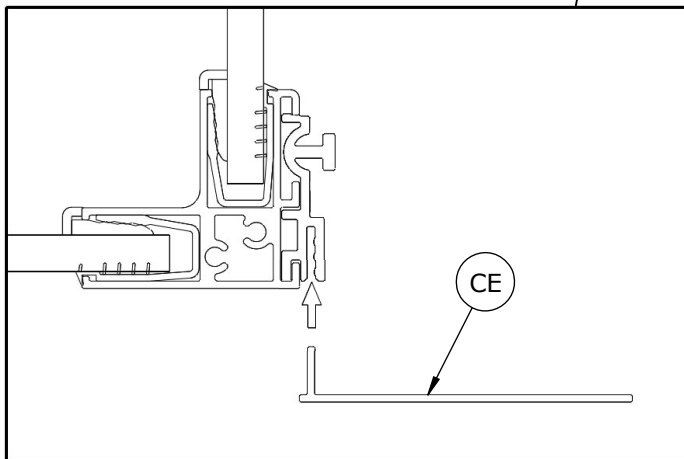
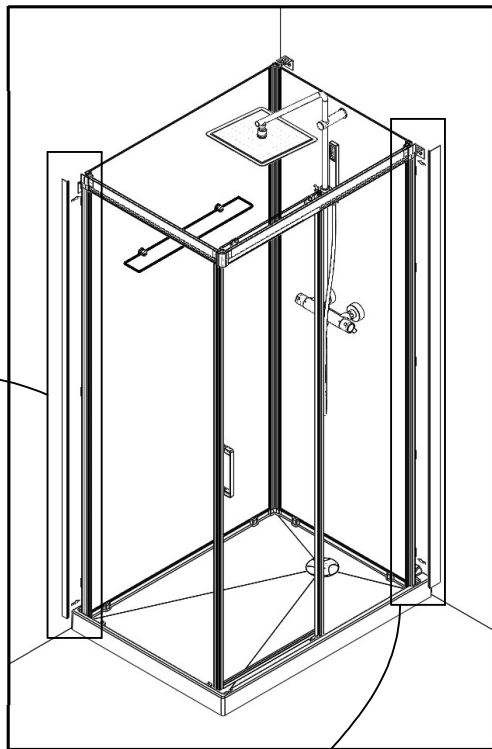
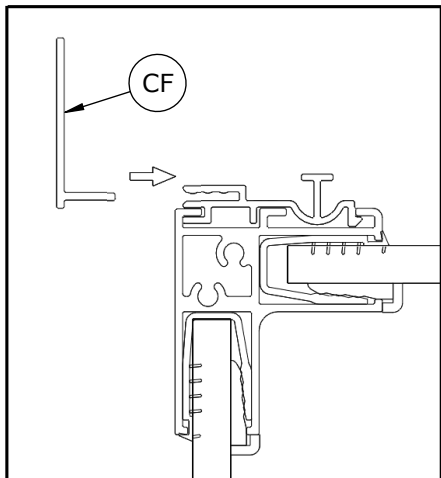



SAV
SERVICE HELPLINES
ASSISTENZA POST-VENDITA
SERVICIO POSTVENTA

FRANCE

02 40 21 29 45

SCHWEIZ

(01) 748 17 44

UK

020 8842 0033

ESPANA

93 544 60 76

IRELAND

04697 33102

NEDERLAND

+31 475 487 100

DEUTSCHLAND

+49 (0) 6074 / 30928 0

BELGIE

+31 475 487 100

ITALIA

(0382) 6181

BELGIQUE

+31 475 487 100

OSTEREICH

+43 1 710 60 70

РОССИЯ

963 19 40, 773 67 22